

# KONTROL $H_2$ DAN KONTROL $H_\infty$ SERTA APLIKASINYA DALAM SISTEM MASSA PEGAS



---

**KARTIKA YULIANTI (20106010)**

**RIRIN SISPIYATI (20106003)**



## KONTROL $H_2$ DAN KONTROL $H_\infty$ SERTA APLIKASINYA DALAM SISTEM MASSA PEGAS

- Pendahuluan
- Kontrol  $H_2$
- Kontrol  $H_\infty$
- Aplikasi
- Kesimpulan



# Pendahuluan

---

Tujuan:

Membandingkan Kontrol  $H_2$  dengan  
Kontrol  $H_\infty$

# Kontrol $H_2$

Matrik transfer:

$$G(s) = \left[ \begin{array}{c|cc} A & B_1 & B_2 \\ \hline C_1 & 0 & D_{12} \\ C_2 & D_{21} & 0 \end{array} \right].$$

Asumsi-asumsi untuk penyederhanaan masalah:

- $(A, B_2)$  terstabilkan dan  $(C_2, A)$  terdeteksi;
- $R_1 = D_{12}^* D_{12} > 0$  dan  $R_2 = D_{21} D_{21}^* > 0$
- $\begin{bmatrix} A - j\omega I & B_2 \\ C_1 & D_{12} \end{bmatrix}$  mempunyai rank kolom penuh untuk setiap  $\omega$
- $\begin{bmatrix} A - j\omega I & B_1 \\ C_2 & D_{21} \end{bmatrix}$  mempunyai rank kolom penuh untuk setiap  $\omega$





# Kontrol $H_2$ (Definisi)

---

**Masalah utama kontrol**  $H_2$  adalah mencari pengontrol  $K$  yang proper dan real rational yang menstabilkan  $G$  secara internal dan meminimumkan  $H_2$  norm dari transfer matriks  $T_{zw}$  dari  $w$  ke  $z$ .

# Kontrol $H_2$ (Solusi)

$$\begin{aligned} H_2 &= \begin{bmatrix} A & 0 \\ -C_1^* C_1 & -A^* \end{bmatrix} - \begin{bmatrix} B_2 \\ -C_1^* D_{12} \end{bmatrix} R_1^{-1} \begin{bmatrix} D_{12}^* C_1 & B_2^* \end{bmatrix} \\ &= \begin{bmatrix} A - B_2 R_1^{-1} D_{12}^* C_1 & -B_2 R_1^{-1} B_2^* \\ -C_1^* (I - D_{12} R_1^{-1} D_{12}^*) C_1 & -(A - B_2 R_1^{-1} D_{12}^* C_1)^* \end{bmatrix} \end{aligned}$$

$H_2$  anggota  $\text{dom}(\text{Ric})$  dan  $X_2 = \text{Ric}(H_2) \geq 0$

$$\begin{aligned} J_2 &= \begin{bmatrix} A^* & 0 \\ -B_1 B_1^* & -A \end{bmatrix} - \begin{bmatrix} C_2^* \\ -B_1 D_{21}^* \end{bmatrix} R_2^{-1} \begin{bmatrix} D_{21} B_1^* & C_2 \end{bmatrix} \\ &= \begin{bmatrix} (A - B_1 D_{21}^* R_2^{-1} C_2)^* & -C_2^* R_2^{-1} C_2 \\ -B_1 (I - D_{21}^* R_2^{-1} D_{21}) B_1^* & -(A - B_1 D_{21}^* R_2^{-1} C_2) \end{bmatrix} \end{aligned}$$

$H_2$  anggota  $\text{dom}(\text{Ric})$  dan  $Y_2 = \text{Ric}(J_2) \geq 0$

# Kontrol $H_\infty$ (Masalah Sederhana)

Matrik transfer:

$$G(s) = \left[ \begin{array}{c|cc} A & B_1 & B_2 \\ \hline C_1 & 0 & D_{12} \\ C_2 & D_{21} & 0 \end{array} \right].$$

Asumsi-asumsi untuk penyederhanaan masalah:

- $(A, B_1)$  terkontrol dan  $(C_1, A)$  terobservasi;
- $(A, B_2)$  terstabilkan dan  $(C_2, A)$  terdeteksi;

- $D_{12}^* [C_1 \quad D_{12}] = [0 \quad I];$

- $\begin{bmatrix} B_1 \\ D_{21} \end{bmatrix} D_{21}^* = \begin{bmatrix} 0 \\ I \end{bmatrix}.$



# Kontrol $H_\infty$

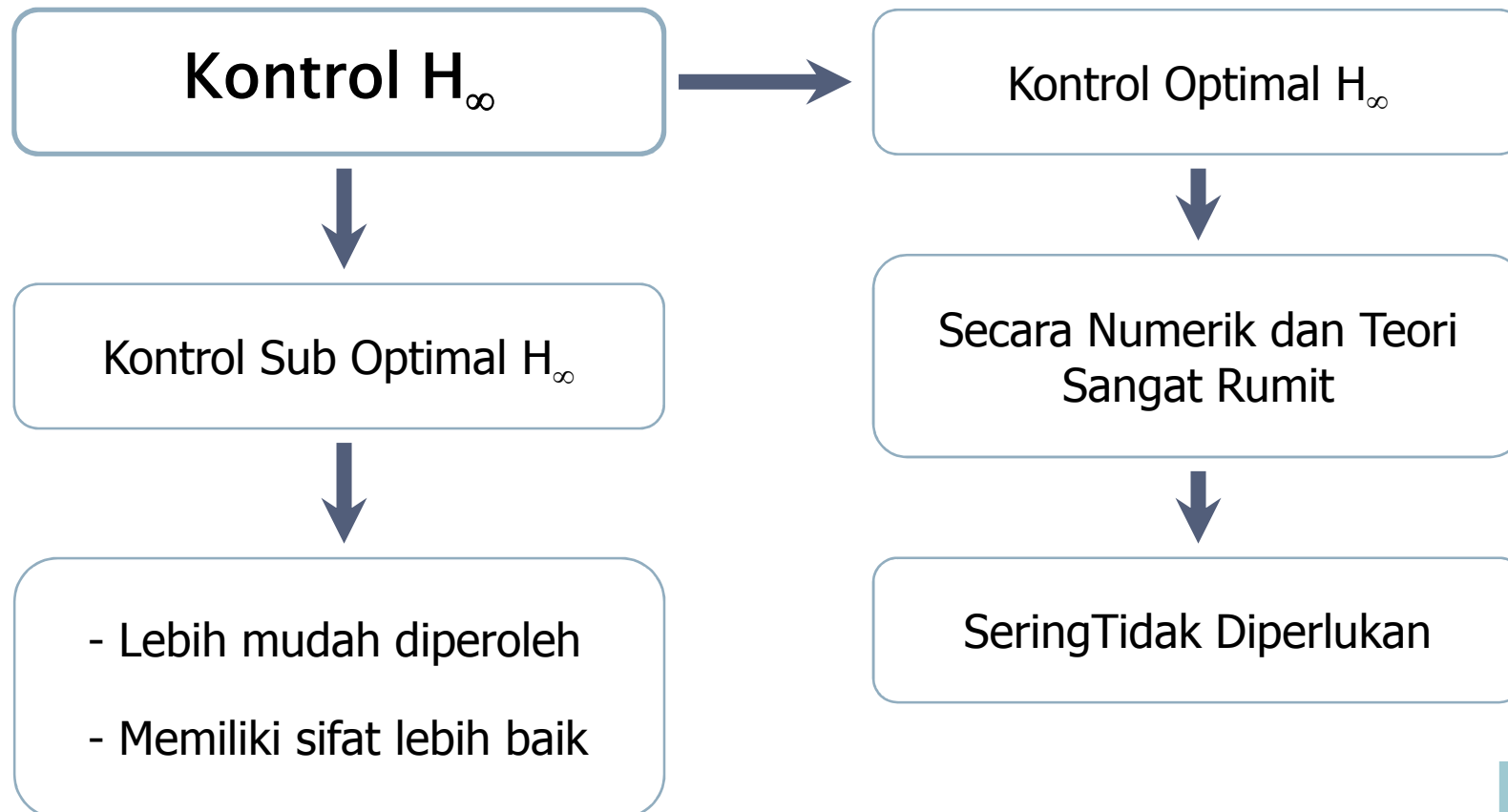





# Kontrol $H_\infty$ (Definisi)

---

- **Kontrol Optimal:** mencari semua pengontrol  $K(s)$ , sedemikian sehingga diperoleh  $\|T_{zw}\|_\infty$  minimal.
- **Kontrol Suboptimal:** diberikan  $\gamma > 0$  mencari semua pengontrol  $K(s)$  yang dapat diterima, sedemikian sehingga

$$\|T_{zw}\|_\infty < \gamma$$



# Kontrol $H_\infty$ (Masalah Sederhana)

Matrik transfer:

$$G(s) = \left[ \begin{array}{c|cc} A & B_1 & B_2 \\ \hline C_1 & 0 & D_{12} \\ C_2 & D_{21} & 0 \end{array} \right].$$

Asumsi-asumsi untuk penyederhanaan masalah:

- $(A, B_1)$  terkontrol dan  $(C_1, A)$  terobservasi;
- $(A, B_2)$  terstabilkan dan  $(C_2, A)$  terdeteksi;

- $D_{12}^* [C_1 \quad D_{12}] = [0 \quad I];$

- $\begin{bmatrix} B_1 \\ D_{21} \end{bmatrix} D_{21}^* = \begin{bmatrix} 0 \\ I \end{bmatrix}.$





# Kontrol $H_\infty$ (Solusi Hamiltonian)

---

$$H_\infty := \begin{bmatrix} A & \gamma^{-2} B_1 B_1^* - B_2 B_2^* \\ -C_1^* C_1 & -A_1^* \end{bmatrix}$$

$$J_\infty := \begin{bmatrix} A^* & \gamma^{-2} C_1^* C_1 - C_2^* C_2 \\ -B_1 B_1^* & -A \end{bmatrix}$$





# Kontrol $H_\infty$ (Eksistensi Pengontrol Suboptimal)

---

Teorema : Terdapat suatu pengontrol yang dapat diterima sedemikian sehingga  $\|T_{zw}\|_\infty < \gamma$  jika dan hanya jika tiga kondisi berikut terpenuhi:

- $H_\infty \in \text{dom}(\text{Ric})$  dan  $X_\infty := \text{Ric}(H_\infty) \geq 0$ .
- $J_\infty \in \text{dom}(\text{Ric})$  dan  $Y_\infty := \text{Ric}(J_\infty) \geq 0$ .
- $\rho(X_\infty, Y_\infty) < \gamma^2$ .



# Kontrol $H_\infty$ (Eksistensi Pengontrol Suboptimal)

Jika ketiga kondisi dipenuhi, maka

$$K_{sub}(s) := \left[ \begin{array}{c|c} \hat{A}_\infty & -Z_\infty L_\infty \\ \hline F_\infty & 0 \end{array} \right]$$

dengan

$$\hat{A}_\infty := A + \gamma^{-2} B_1 B_1^* X_\infty + B_2 F_\infty + Z_\infty L_\infty C_2$$

$$F_\infty := -B_2^* X_\infty, \quad L_\infty := Y_\infty C_2^*, \quad Z_\infty := (I - \gamma^{-2} Y_\infty X_\infty)^{-1}.$$



# Perbandingan

Kontrol $H_2$	Kontrol $H_\infty$
<ul style="list-style-type: none"><li>■ Kontrol optimal <math>H_2</math> Tunggal</li><li>■ T.12.4 menjamin matriks Hamiltonian <math>H_2</math> anggota <math>\text{dom}(\text{Ric})</math></li></ul>	<ul style="list-style-type: none"><li>■ Kontrol optimal <math>H_\infty</math> tidak Tunggal untuk sistem MIMO</li><li>■ Blok (1,2) dari matriks Hamiltonian tidak sign definite (Tidak bisa menggunakan T.12.4)</li><li>■ <math>\gamma \rightarrow \infty</math> maka matriks Hamiltonian <math>H_\infty</math> berkoresponden dengan matriks Hamiltonian <math>H_2</math></li></ul>

# Aplikasi (Sistem Massa Pegas)

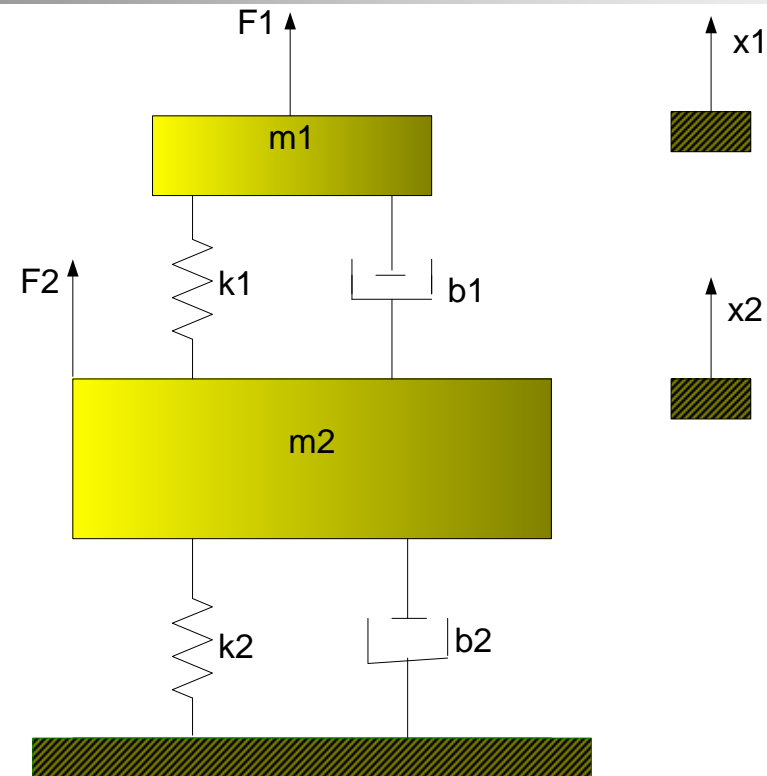

**Model Sistem Massa Pegas**

# State-Space Sistem Massa Pegas

- Berdasarkan Hukum Kedua Newton dan hukum kedua Hooke

$$m_1 \ddot{x}_1 = b_1 (\dot{x}_2 - \dot{x}_1) - k_1 x_1 + k_2 x_2 + F_1$$

$$m_2 \ddot{x}_2 = b_1 \dot{x}_1 - (b_1 + b_2) \dot{x}_2 + k_1 x_1 + (k_1 + k_2) x_2 + F_2$$

- Jika  $x_3 = \dot{x}_1$  dan  $x_4 = \dot{x}_2$  maka

$$\dot{x}_3 = -\frac{k_1}{m_1} x_1 + \frac{k_2}{m_1} x_2 - \frac{b_1}{m_1} x_3 + \frac{b_1}{m_1} x_4 + \frac{F_1}{m_1}$$

$$\dot{x}_4 = \frac{k_1}{m_2} x_1 + \frac{k_1 + k_2}{m_2} x_2 + \frac{b_1}{m_2} x_3 - \frac{b_1 + b_2}{m_2} x_4 + \frac{F_2}{m_2}$$





# State-Space Sistem Massa Pegas

$$\dot{x}_p = \begin{bmatrix} \dot{x}_1 \\ \dot{x}_2 \\ \dot{x}_3 \\ \dot{x}_4 \end{bmatrix} = \begin{bmatrix} 0 & 0 & 1 & 0 \\ 0 & 0 & 0 & 1 \\ -\frac{k_1}{m_1} & \frac{k_1}{m_1} & -\frac{b_1}{m_1} & \frac{b_1}{m_1} \\ \frac{k_1}{m_2} & -\frac{k_1+k_2}{m_2} & \frac{b_1}{m_2} & -\frac{b_1+b_2}{m_2} \end{bmatrix} \begin{bmatrix} x_1 \\ x_2 \\ x_3 \\ x_4 \end{bmatrix} + \begin{bmatrix} 0 & 0 \\ 0 & 0 \\ \frac{1}{m_1} & 0 \\ 0 & \frac{1}{m_2} \end{bmatrix} \begin{bmatrix} F_1 \\ F_2 \end{bmatrix}$$

$$\begin{bmatrix} x_1 \\ x_2 \end{bmatrix} = \begin{bmatrix} 1 & 0 & 0 & 0 \\ 0 & 1 & 0 & 0 \end{bmatrix} \begin{bmatrix} x_1 \\ x_2 \\ x_3 \\ x_4 \end{bmatrix}$$



# State-Space Sistem Massa Pegas

Diberikan nilai:

$$k_1 = 1, \quad k_2 = 4, \quad b_1 = 0.2, \quad b_2 = 0.1, \quad m_1 = 1, \quad \text{dan} \quad m_2 = 2$$

State space dapat dinotasikan:

$$\dot{x}_p = A_p x_p + B_p U$$

$$y_p = C_p x_p + D_p U$$

dengan

$$A_p = \begin{bmatrix} 0 & 0 & 1 & 0 \\ 0 & 0 & 0 & 1 \\ -1 & 1 & -0.2 & 0.1 \\ 0.5 & -2.5 & 0.1 & -0.15 \end{bmatrix},$$

$$B_p = \begin{bmatrix} 0 & 0 \\ 0 & 0 \\ 1 & 0 \\ 0 & 0.5 \end{bmatrix}$$

$$C_p = \begin{bmatrix} 1 & 0 & 0 & 0 \\ 0 & 1 & 0 & 0 \end{bmatrix}$$

$$D_p = \begin{bmatrix} 0 & 0 \\ 0 & 0 \end{bmatrix}$$



# Fungsi Bobot

$$W_i = \left[ \begin{array}{c|c} A_i & B_i \\ \hline C_i & D_i \end{array} \right] = \left[ \begin{array}{cc|cc} -10 & 0 & 1 & 0 \\ 0 & -10 & 0 & 1 \\ \hline 3 & 0 & 1 & 0 \\ 0 & -3 & 0 & 1 \end{array} \right]$$

$$W_o = \begin{bmatrix} \frac{-5}{s+1} & 0 \\ 0 & \frac{-5}{s+1} \end{bmatrix} \Leftrightarrow W_o = \left[ \begin{array}{c|c} A_o & B_o \\ \hline C_o & D_o \end{array} \right] = \left[ \begin{array}{cc|cc} -1 & 0 & 2.236 & 0 \\ 0 & -1 & 0 & 2.236 \\ \hline -2.236 & 0 & 0 & 0 \\ 0 & -2.236 & 0 & 0 \end{array} \right]$$

$$W_n = \begin{bmatrix} \frac{0.01(s+10)}{s+100} & 0 \\ 0 & \frac{0.01(s+10)}{s+100} \end{bmatrix} \Leftrightarrow W_n = \left[ \begin{array}{c|c} A_n & B_n \\ \hline C_n & D_n \end{array} \right] = \left[ \begin{array}{cc|cc} -100 & 0 & 0.949 & 0 \\ 0 & -100 & 0 & 0.949 \\ \hline -0.949 & 0 & 0.01 & 0 \\ 0 & -0.949 & 0 & 0.01 \end{array} \right]$$



# Blok Diagram dan Sistem Loop Tertutup pada Sistem Massa Pegas

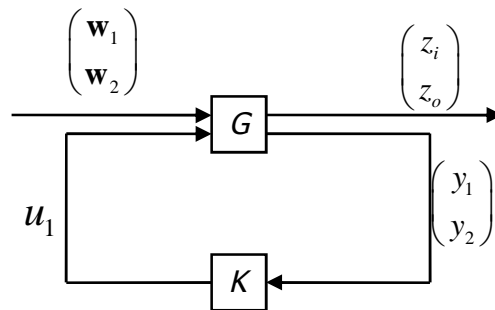
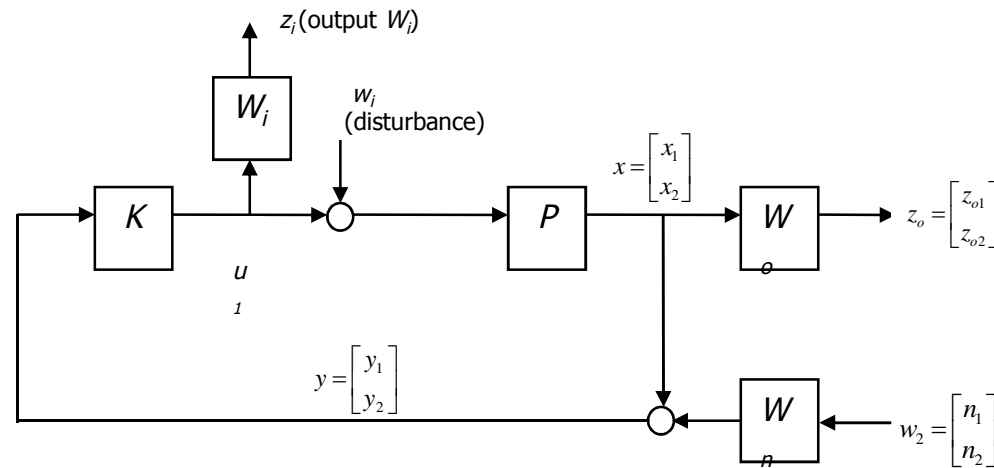

# State Space dari Fungsi Bobot

- Untuk  $W_i$

$$\dot{x}_i = A_i x_i + B_i u_1$$

$$z_i = C_i x_i + D_i u_1$$

- Untuk  $W_o$

$$\dot{x}_o = A_o x_o + B_o \mathbf{x} = A_o x_o + B_o (C_p x_p + D_p (u_1 + \mathbf{w}_1))$$

$$z_o = C_o x_o + D_o \mathbf{x} = C_o x_o + D_o (C_p x_p + D_p (u_1 + \mathbf{w}_1))$$

- Untuk  $W_n$

$$\dot{x}_n = A_n x_n + B_n \mathbf{w}_2$$

$$n = C_n x_n + D_n \mathbf{w}_2$$

Untuk P

$$\dot{x}_p = A_p x_p + B_p u_1 + B_p w_1$$

$$y_p = C_p x_p + D_p u_1 + D_p w_1$$



# Generalized plant

$$\dot{x} = \begin{bmatrix} \dot{x}_i \\ \dot{x}_p \\ \dot{x}_o \\ \dot{x}_n \end{bmatrix} = \begin{bmatrix} A_i & 0 & 0 & 0 \\ 0 & A_p & 0 & 0 \\ 0 & B_o C_p & A_o & 0 \\ 0 & 0 & 0 & A_n \end{bmatrix} \begin{bmatrix} x_i \\ x_p \\ x_o \\ x_n \end{bmatrix} + \begin{bmatrix} 0 & 0 \\ B_p & 0 \\ D_p & 0 \\ 0 & B_n \end{bmatrix} \begin{bmatrix} w_1 \\ w_2 \end{bmatrix} + \begin{bmatrix} B_i \\ B_p \\ D_p \\ 0 \end{bmatrix} u_1$$

$$z = \begin{bmatrix} z_i \\ z_o \end{bmatrix} = \begin{bmatrix} C_i & 0 & 0 & 0 \\ 0 & D_o C_p & C_o & 0 \end{bmatrix} \begin{bmatrix} x_i \\ x_p \\ x_o \\ x_n \end{bmatrix} + \begin{bmatrix} 0 & 0 \\ D_o D_p & 0 \end{bmatrix} \begin{bmatrix} w_1 \\ w_2 \end{bmatrix} + \begin{bmatrix} D_i \\ D_o D_p \end{bmatrix} u_1 \quad \Leftrightarrow \quad G(s) = \left[ \begin{array}{c|cc} A & B_1 & B_2 \\ \hline C_1 & D_{11} & D_{12} \\ C_2 & D_{21} & D_{22} \end{array} \right]$$

$$y = x + n = \begin{bmatrix} 0 & C_p & 0 & C_n \end{bmatrix} \begin{bmatrix} x_i \\ x_p \\ x_o \\ x_n \end{bmatrix} + \begin{bmatrix} D_p & D_n \end{bmatrix} \begin{bmatrix} w_1 \\ w_2 \end{bmatrix} + D_p u_1$$





# Kesimpulan

---

- Untuk kontrol  $H_2$  dengan nilai norm:

$$\|T_{zw}\|_2 = 1.7361$$

- Untuk kontrol  $H_\infty$  dengan nilai norm:

$$\|T_{zw}\|_\infty = 0.9515$$