

Contoh
Penghitungan Sambungan

Soal 1

Diketahui: data spt pada gbr di bawah

$$P_1 = 1500 \text{ kg}$$

$$P_2 = 2500 \text{ kg}$$

$$\bar{\sigma} = 1400 \text{ kg/cm}^2$$

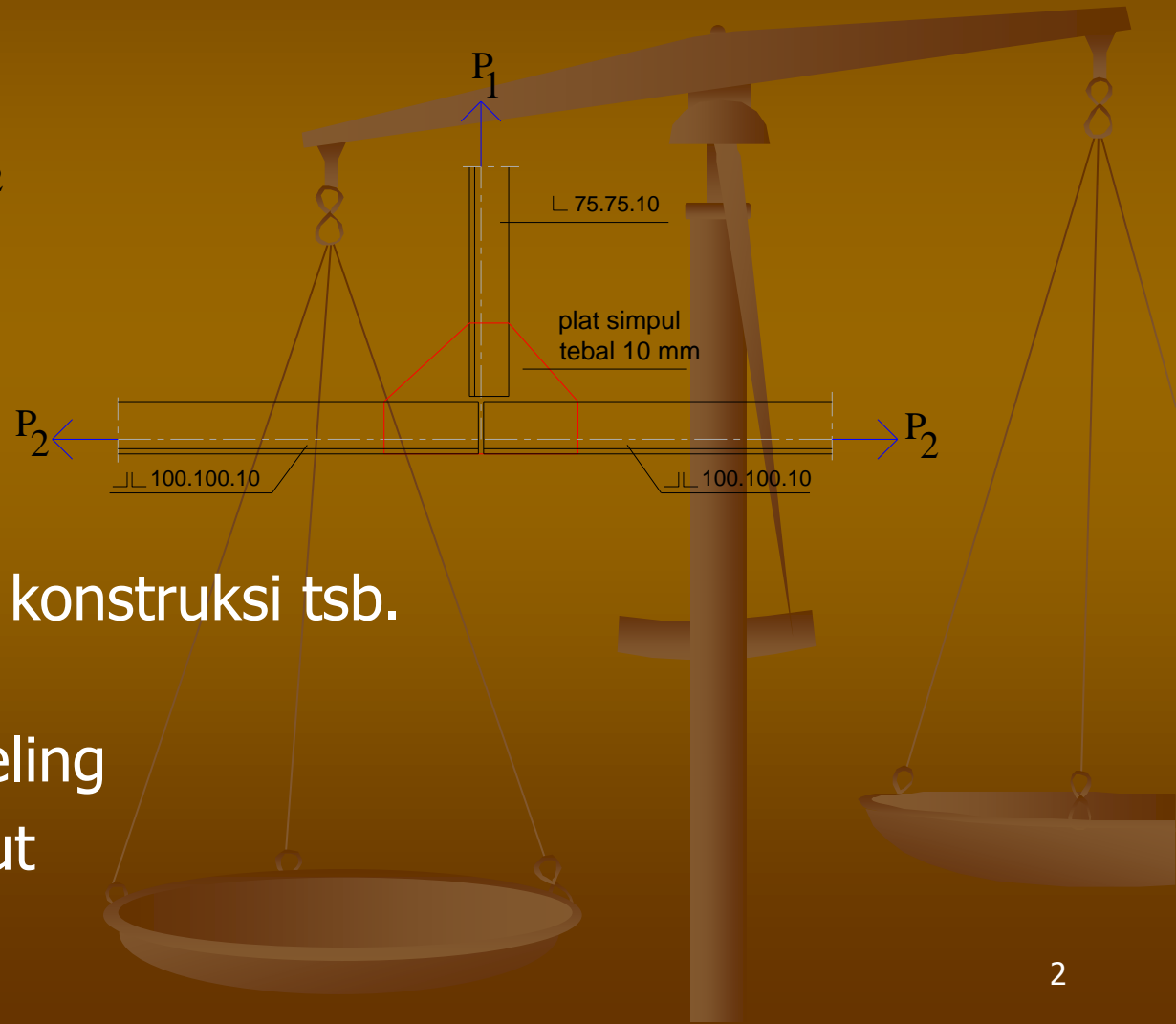

Hitung sambungan konstruksi tsb.

dengan: a) bout

b) paku keling

c) las sudut

Penyelesaian

a) Sambungan bout:

$$\bar{\sigma}_{tp} = 1,5\bar{\sigma} = 1,5 \times 1400 \text{ kg/cm}^2 = 2100 \text{ kg/cm}^2$$

$$\bar{\tau} = 0,6\bar{\sigma} = 0,6 \times 1400 \text{ kg/cm}^2 = 840 \text{ kg/cm}^2$$

Sambungan batang datar dengan plat simpul

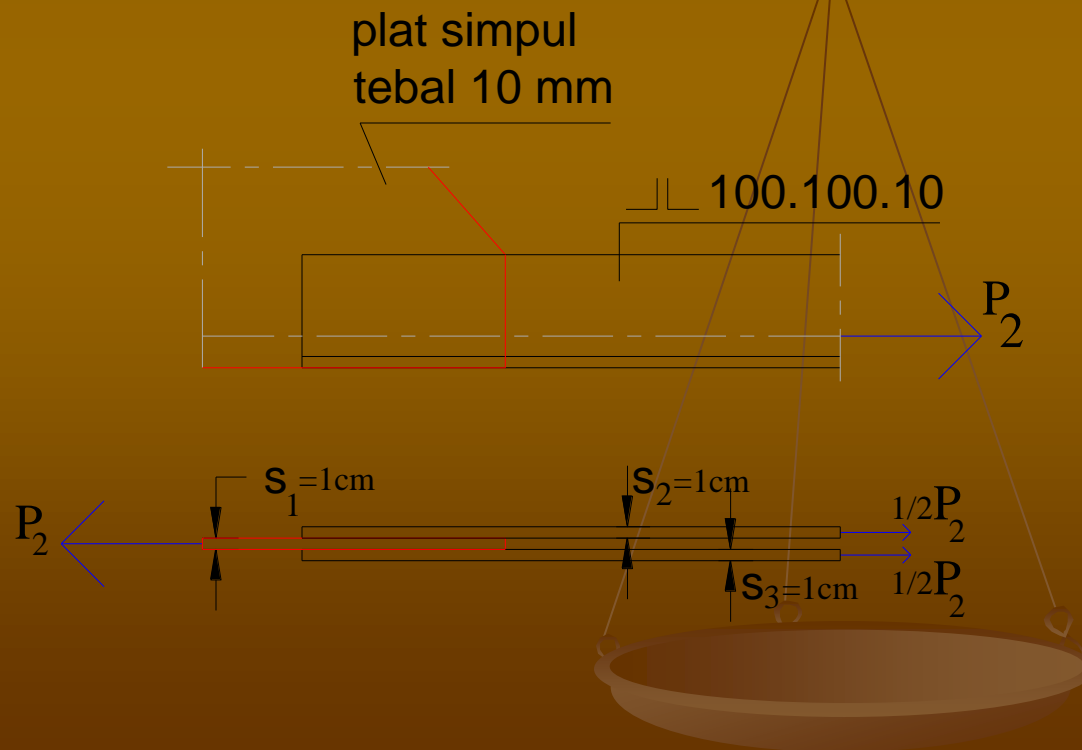

$$s_1 < s_2 + s_3 \rightarrow s_1 = s_{\min} = 1 \text{ cm}$$

$$\text{Bout } \varnothing \frac{3}{4}'' \rightarrow d = 19,7 \text{ mm}$$

Sambungan dobel

$$N_{gs} = 2 \cdot \frac{1}{4} \pi d^2 \bar{\tau} = 2 \cdot \frac{1}{4} \cdot 3,14 \times (1,97 \text{ cm})^2 \times 840 \text{ kg/cm}^2 = 5118 \text{ kg}$$

$$N_{tp} = d \cdot s_{\min} \bar{\sigma}_{tp} = 1,97 \text{ cm} \times 1 \text{ cm} \times 2100 \text{ kg/cm}^2 = 4137 \text{ kg}$$

$$N_{\min} = N_{tp} = 4137 \text{ kg}$$

$$n = \frac{P_2}{N_{\min}} = \frac{2500 \text{ kg}}{4137 \text{ kg}} = 0,604 \approx 1$$

\Rightarrow ambil $2\varnothing \frac{1}{4}''$

Sambungan batang tegak dengan plat simpul

Sambungan tunggal

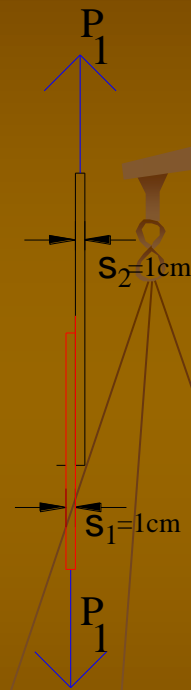
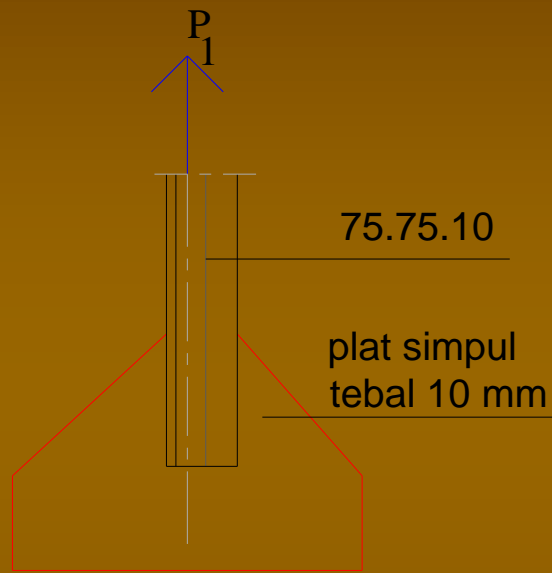

$$s_1 = s_2 = 1 \text{ cm} = s_{\min}$$

$$\text{Bout } \varnothing \frac{3}{4}'' \rightarrow d = 19,7 \text{ mm}$$



$$N_{gs} = \frac{1}{4} \pi d^2 \bar{\tau} = \frac{1}{4} \cdot 3,14 \times (1,97 \text{ cm})^2 \times 840 \text{ kg/cm}^2 = 2559 \text{ kg}$$

$$N_{tp} = d \cdot s_{\min} \bar{\sigma}_{tp} = 1,97 \text{ cm} \times 1 \text{ cm} \times 2100 \text{ kg/cm}^2 = 4137 \text{ kg}$$

$$N_{\min} = N_{gs} = 2559 \text{ kg}$$

$$n = \frac{P_2}{N_{\min}} = \frac{1500 \text{ kg}}{2559 \text{ kg}} = 0,586 \approx 1$$

\Rightarrow ambil $2\phi \frac{1}{4}$ "

Gambar sket sambungan bout

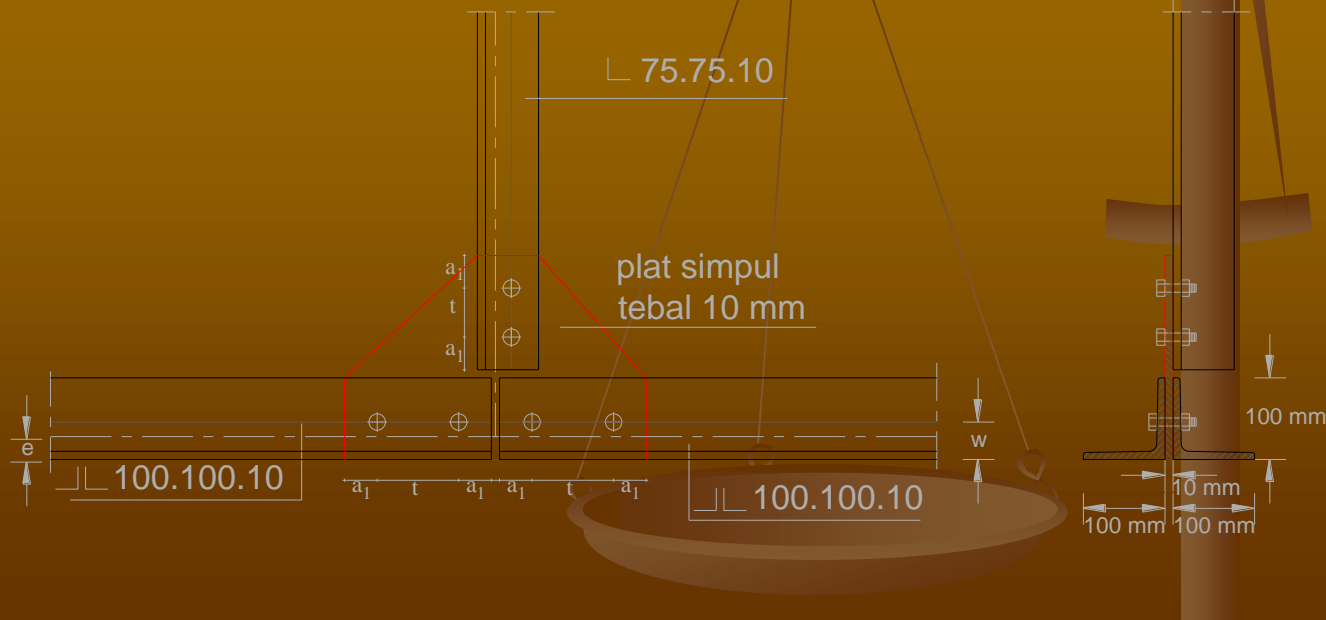

b) Sambungan paku keling:

$$\bar{\sigma}_{tp} = 2\bar{\sigma} = 2 \times 1400 \text{ kg/cm}^2 = 2800 \text{ kg/cm}^2$$

$$\bar{\tau} = 0,8\bar{\sigma} = 0,8 \times 1400 \text{ kg/cm}^2 = 1120 \text{ kg/cm}^2$$

Sambungan batang datar dengan plat simpul

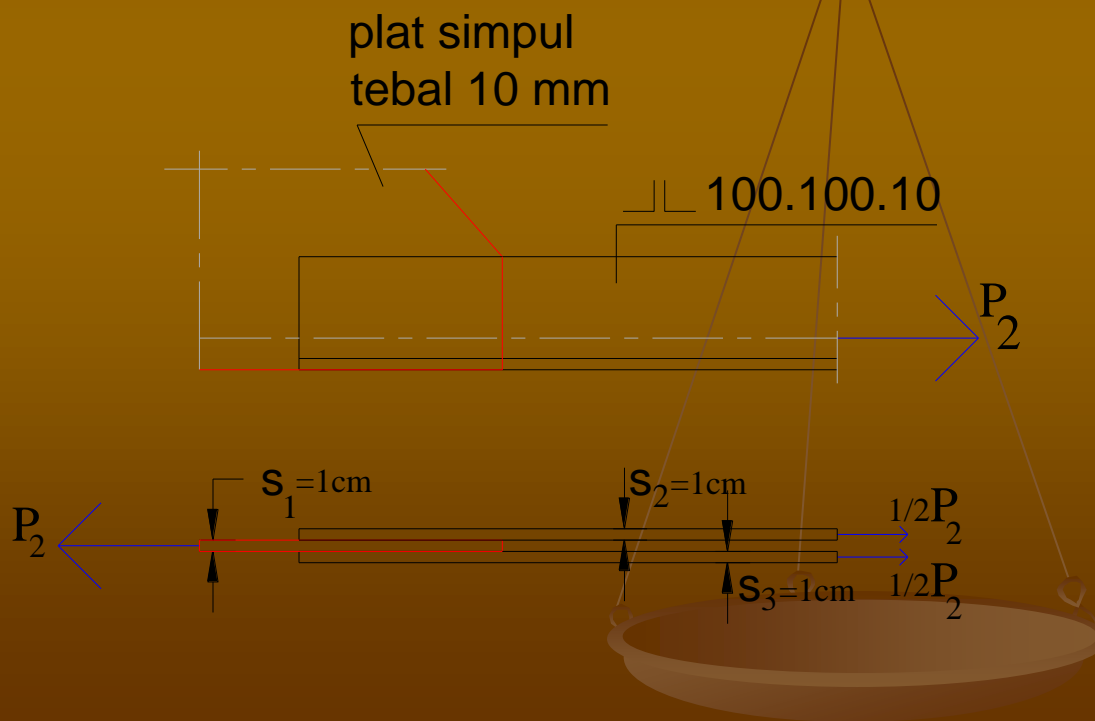

$s_1 < s_2 + s_3 \rightarrow s_1 = s_{\min} = 1 \text{ cm}$
pk $\emptyset 20 \text{ mm}$ (lubang)

Sambungan dobel

$$N_{gs} = 2 \cdot \frac{1}{4} \pi d^2 \bar{\tau} = 2 \cdot \frac{1}{4} \cdot 3,14 \times (2 \text{ cm})^2 \times 1120 \text{ kg/cm}^2 = 7034 \text{ kg}$$

$$N_{tp} = d \cdot s_{\min} \bar{\sigma}_{tp} = 2 \text{ cm} \times 1 \text{ cm} \times 2800 \text{ kg/cm}^2 = 5600 \text{ kg}$$

$$N_{\min} = N_{tp} = 5600 \text{ kg}$$

$$n = \frac{P_2}{N_{\min}} = \frac{2500 \text{ kg}}{5600 \text{ kg}} = 0,446 \approx 1$$

\Rightarrow ambil $2\emptyset 20 \text{ mm}$

Sambungan batang tegak dengan plat simpul

Sambungan tunggal

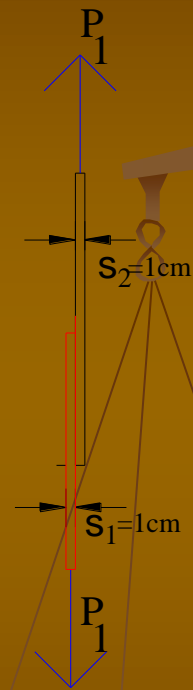
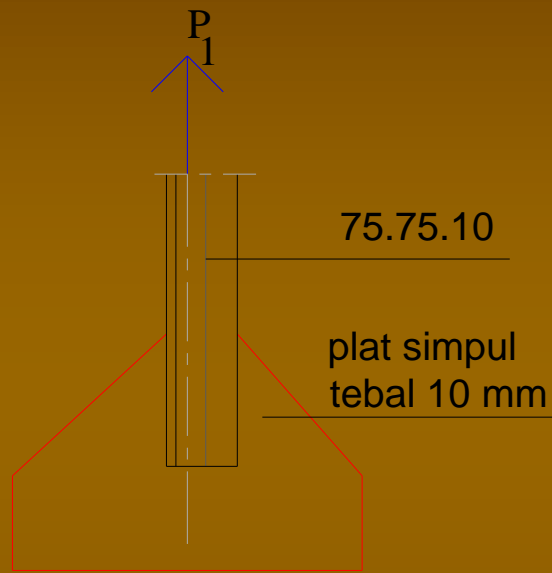

$s_1 = s_2 = 1\text{ cm} = s_{\min}$
pk $\varnothing 20\text{ mm}$ (lubang)

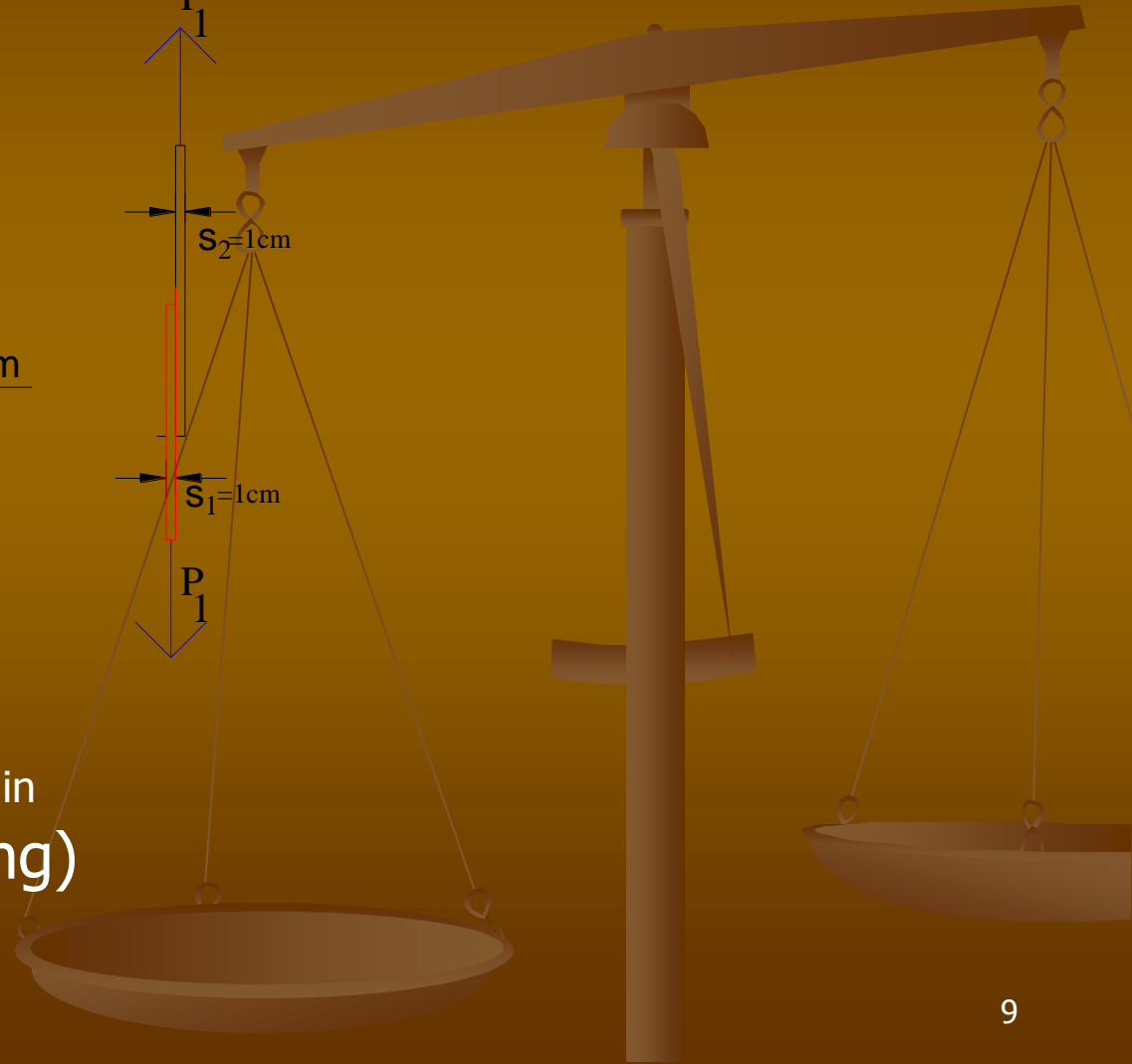

$$N_{gs} = \frac{1}{4} \pi d^2 \bar{\tau} = \frac{1}{4} \cdot 3,14 \times (2\text{cm})^2 \times 1120 \text{kg/cm}^2 = 3517 \text{kg}$$

$$N_{tp} = d \cdot s_{\min} \bar{\sigma}_{tp} = 2\text{cm} \times 1\text{cm} \times 2800 \text{kg/cm}^2 = 5600 \text{kg}$$

$$N_{\min} = N_{gs} = 3517 \text{kg}$$

$$n = \frac{P_2}{N_{\min}} = \frac{1500 \text{kg}}{3517 \text{kg}} = 0,426 \approx 1 \Rightarrow \text{ambil } 2\phi 20 \text{mm}$$

Gambar sket sambungan pk

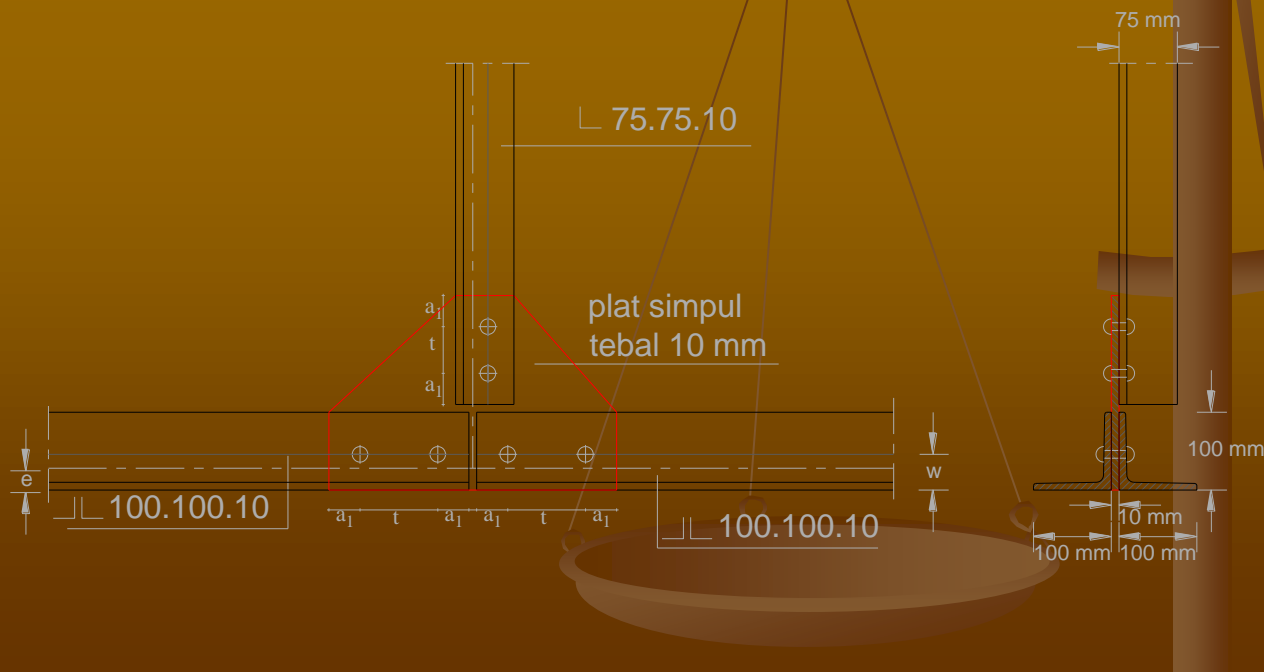

c) Sambungan las sudut

Sambungan batang datar dengan plat simpul

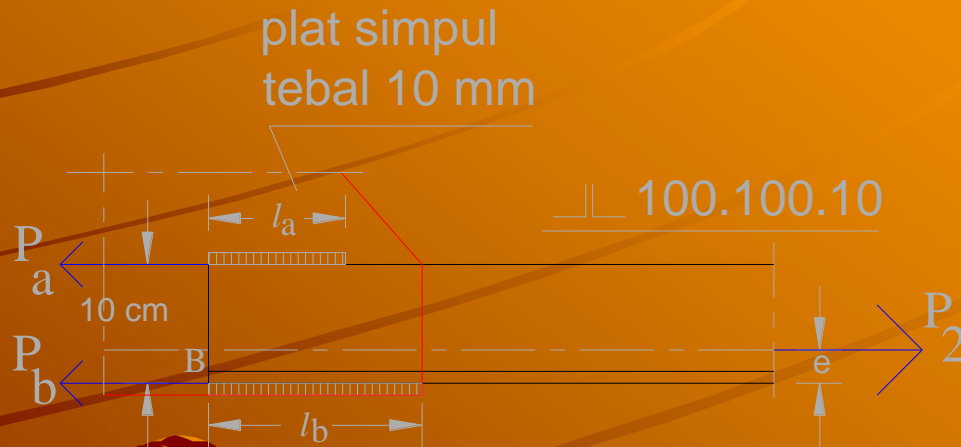

$$\bar{\tau} = 0,6\bar{\sigma} = 840 \text{ kg/cm}^2$$

Dari tabel profil, utk L 100.100.10 didapat:

$$b = 100 \text{ mm} = 10 \text{ cm}; d = 10 \text{ mm} = 1 \text{ cm}; e = 2,82 \text{ cm}$$

2 baja L 100.100.10 menahan gaya P₂

1 baja L 100.100.10 menahan gaya P = P₂/2 →

$$P = 2500 \text{ kg}/2 = 1250 \text{ kg}$$

$$d = 1 \text{ cm} \rightarrow a = 0,707d$$

$$a = 0,707 \times 1 \text{ cm} = 0,707 \text{ cm}$$

$$b - e = 10 \text{ cm} - 2,82 \text{ cm} = 7,18 \text{ cm}$$

$$\Sigma M_B = 0$$

$$P_a \cdot b - P \cdot e = 0$$

$$P_a = \frac{P \cdot e}{b} = \frac{1250 \text{ kg} \times 2,82 \text{ cm}}{10 \text{ cm}} = 352,5 \text{ kg}$$

$$\Sigma H = 0$$

$$P_a + P_b - P = 0$$

$$P_b = P - P_a$$

$$P_b = 1250 \text{ kg} - 352,5 \text{ kg} = 897,5 \text{ kg}$$

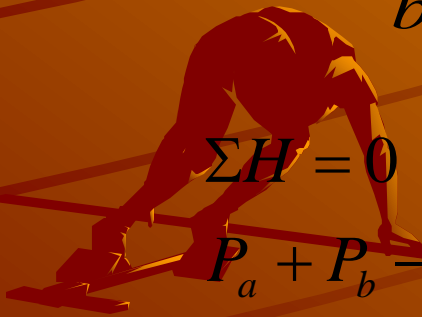

$$\tau_a = \frac{P_a}{F_{gsa}} \Rightarrow \text{ambil } \tau_a = \bar{\tau} = 840 \text{ kg/cm}^2$$

$$F_{gsa} = \frac{P_a}{\bar{\tau}} = \frac{352,5 \text{ kg}}{840 \text{ kg/cm}^2} = 0,42 \text{ cm}^2$$

$$F_{gsa} = a.l_{an} = 0,707 \text{ cm}.l_{an}$$

$$0,42 \text{ cm}^2 = 0,707 \text{ cm}.l_{an}$$

$$l_{an} = \frac{0,42 \text{ cm}^2}{0,707 \text{ cm}} = 0,594 \text{ cm}$$

$$l_{abr} = l_{an} + 3a = 0,594 \text{ cm} + (3 \times 0,707 \text{ cm})$$

$$l_{abr} = 2,715 \text{ cm} < l_{\min} = 4 \text{ cm} \Rightarrow \text{ambil } l_{abr} = 4 \text{ cm}$$

panjang las atas = 4 cm



$$\tau_b = \frac{P_b}{F_{gsb}} \Rightarrow \text{ambil } \tau_b = \bar{\tau} = 840 \text{ kg/cm}^2$$

$$F_{gsb} = \frac{P_b}{\bar{\tau}} = \frac{897,5 \text{ kg}}{840 \text{ kg/cm}^2} = 1,068 \text{ cm}^2$$

$$F_{gsb} = a.l_{bn} = 0,707 \text{ cm}.l_{bn}$$

$$1,068 \text{ cm}^2 = 0,707 \text{ cm}.l_{bn}$$

$$l_{bn} = \frac{1,068 \text{ cm}^2}{0,707 \text{ cm}} = 1,511 \text{ cm}$$

$$l_{bbr} = l_{bn} + 3a = 1,511 \text{ cm} + (3 \times 0,707 \text{ cm})$$

$$l_{bbr} = 3,632 \text{ cm} < l_{\min} = 4 \text{ cm} \Rightarrow \text{ambil } l_{bbr} = 4 \text{ cm}$$

panjang las bawah = 4 cm



Sambungan batang tegak dengan plat simpul

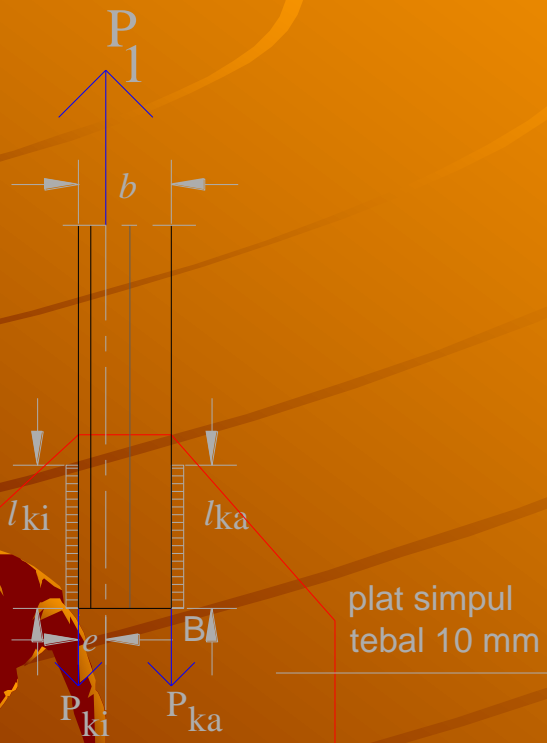

$$\bar{\tau} = 0,6\bar{\sigma} = 840 \text{ kg/cm}^2$$

1 baja L 75.75.10 \rightarrow
 $P_1 = 1500 \text{ kg}$

Dari tabel profil, utk L 75.75.10 didapat:

$$b = 75 \text{ mm} = 7,5 \text{ cm};$$

$$d = 10 \text{ mm} = 1 \text{ cm}; e = 2,21 \text{ cm}$$

$$d = 1 \text{ cm} \rightarrow a = 0,707d$$

$$a = 0,707 \times 1 \text{ cm} = 0,707 \text{ cm}$$

$$b - e = 7,5 \text{ cm} - 2,21 \text{ cm} = 5,29 \text{ cm}$$

$$\Sigma M_B = 0$$

$$P_{ki} \cdot b - P_1 \cdot (b - e) = 0$$

$$P_{ki} = \frac{P_1 \cdot (b - e)}{b} = \frac{1500 \text{ kg} \times 5,29 \text{ cm}}{7,5 \text{ cm}} = 1058 \text{ kg}$$

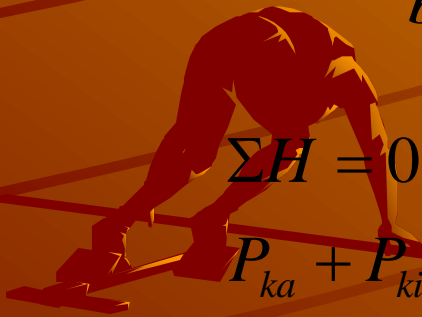

$$\Sigma H = 0$$

$$P_{ka} + P_{ki} - P_1 = 0$$

$$P_{ka} = P_1 - P_{ki}$$

$$P_{ka} = 1500 \text{ kg} - 1058 \text{ kg} = 442 \text{ kg}$$

$$\tau_{ka} = \frac{P_{ka}}{F_{gska}} \Rightarrow \text{ambil } \tau_{ka} = \bar{\tau} = 840 \text{ kg/cm}^2$$

$$F_{gska} = \frac{P_{ka}}{\bar{\tau}} = \frac{442 \text{ kg}}{840 \text{ kg/cm}^2} = 0,526 \text{ cm}^2$$

$$F_{gska} = a.l_{kan} = 0,707 \text{ cm}.l_{kan}$$

$$0,526 \text{ cm}^2 = 0,707 \text{ cm}.l_{kan}$$

$$l_{kan} = \frac{0,526 \text{ cm}^2}{0,707 \text{ cm}} = 0,744 \text{ cm}$$

$$l_{kabr} = l_{kan} + 3a = 0,744 \text{ cm} + (3 \times 0,707 \text{ cm})$$

$$l_{kabr} = 2,865 \text{ cm} < l_{\min} = 4 \text{ cm} \Rightarrow \text{ambil } l_{kabr} = 4 \text{ cm}$$

panjang las kanan = 4 cm



$$\tau_{ki} = \frac{P_{ki}}{F_{gs ki}} \Rightarrow \text{ambil } \tau_{ki} = \bar{\tau} = 840 \text{ kg/cm}^2$$

$$F_{gs ki} = \frac{P_{ki}}{\bar{\tau}} = \frac{1058 \text{ kg}}{840 \text{ kg/cm}^2} = 1,26 \text{ cm}^2$$

$$F_{gs ki} = a.l_{ki n} = 0,707 \text{ cm}.l_{ki n}$$

$$1,26 \text{ cm}^2 = 0,707 \text{ cm}.l_{ki n}$$

$$l_{ki n} = \frac{1,26 \text{ cm}^2}{0,707 \text{ cm}} = 1,782 \text{ cm}$$

$$l_{ki br} = l_{ki n} + 3a = 1,782 \text{ cm} + (3 \times 0,707 \text{ cm})$$

$$l_{ki br} = 3,903 \text{ cm} < l_{\min} = 4 \text{ cm} \Rightarrow \text{ambil } l_{ki br} = 4 \text{ cm}$$

panjang las kiri = 4 cm



Gambar sket sambungan las

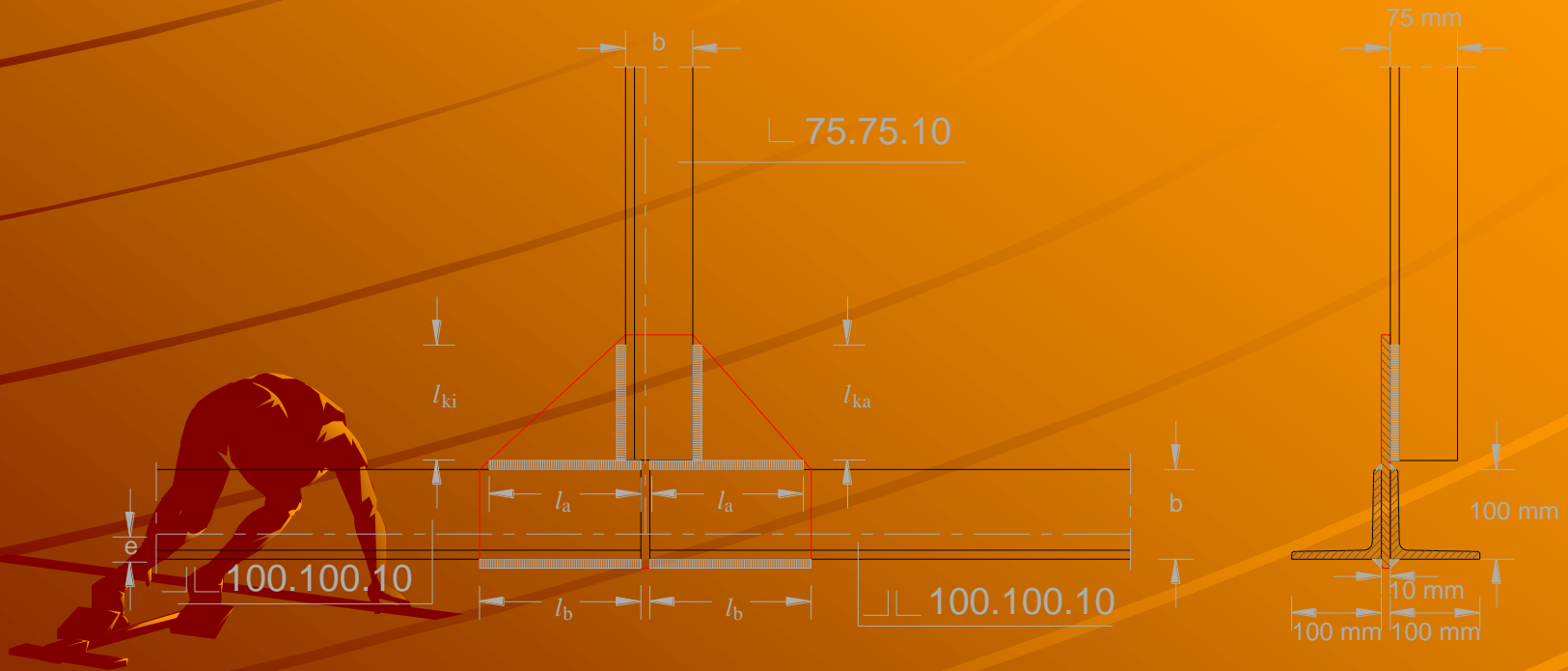

Penyelesaian

a) Sambungan paku keling:

$$\bar{\sigma}_{tp} = 2\bar{\sigma} = 2 \times 1400 \text{ kg/cm}^2 = 2800 \text{ kg/cm}^2$$

$$\bar{\tau} = 0,8\bar{\sigma} = 0,8 \times 1400 \text{ kg/cm}^2 = 1120 \text{ kg/cm}^2$$

Sambungan batang D_1 dengan plat simpul

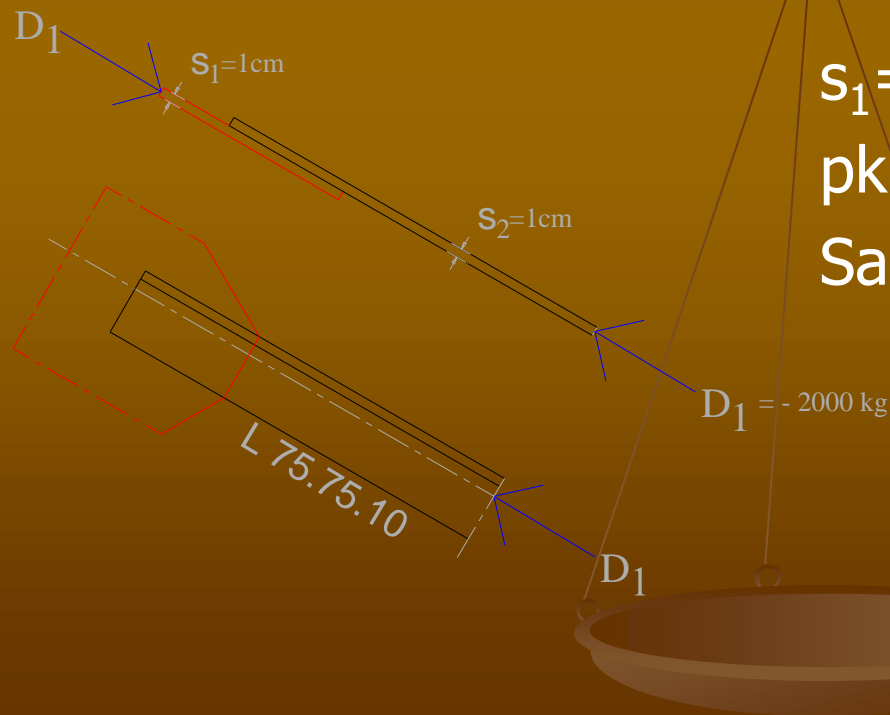

$S_1 = S_2 \rightarrow S_1 = S_{\min} = 1 \text{ cm}$
pk $\varnothing 20 \text{ mm}$ (lubang)
Sambungan tunggal

$$N_{gs} = \frac{1}{4} \pi d^2 \bar{\tau} = \frac{1}{4} \cdot 3,14 \times (2\text{cm})^2 \times 1120\text{kg/cm}^2 = 3517\text{kg}$$

$$N_{tp} = d \cdot s_{\min} \bar{\sigma}_{tp} = 2\text{cm} \times 1\text{cm} \times 2800\text{kg/cm}^2 = 5600\text{kg}$$

$$N_{\min} = N_{gs} = 3517\text{kg}$$

$$n = \frac{P_2}{N_{\min}} = \frac{2000\text{kg}}{3517\text{kg}} = 0,567 \approx 1 \Rightarrow \text{ambil } 2\text{Ø}20\text{mm}$$

Sambungan batang T_1 dengan plat simpul

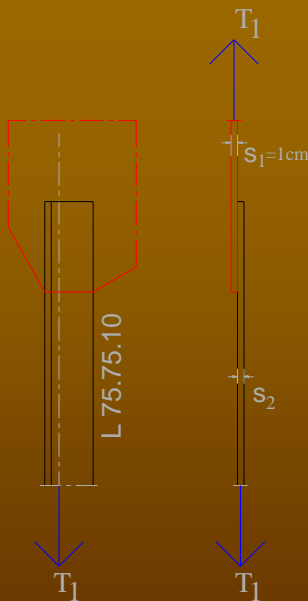

$$s_1 = s_2 \rightarrow s_1 = s_{\min} = 1\text{cm}$$

pk $\text{Ø} 20\text{ mm}$ (lubang)

Sambungan tunggal

$$N_{gs} = 3517\text{kg}$$

$$N_{tp} = 5600\text{kg} \Rightarrow N_{\min} = N_{gs} = 3517\text{kg}$$

$$n = \frac{P_2}{N_{\min}} = \frac{2000\text{kg}}{3517\text{kg}} = 0,567 \approx 1 \Rightarrow \text{ambil } 2\text{Ø}20\text{mm}$$

Sambungan batang A_1/A_2 dengan plat simpul

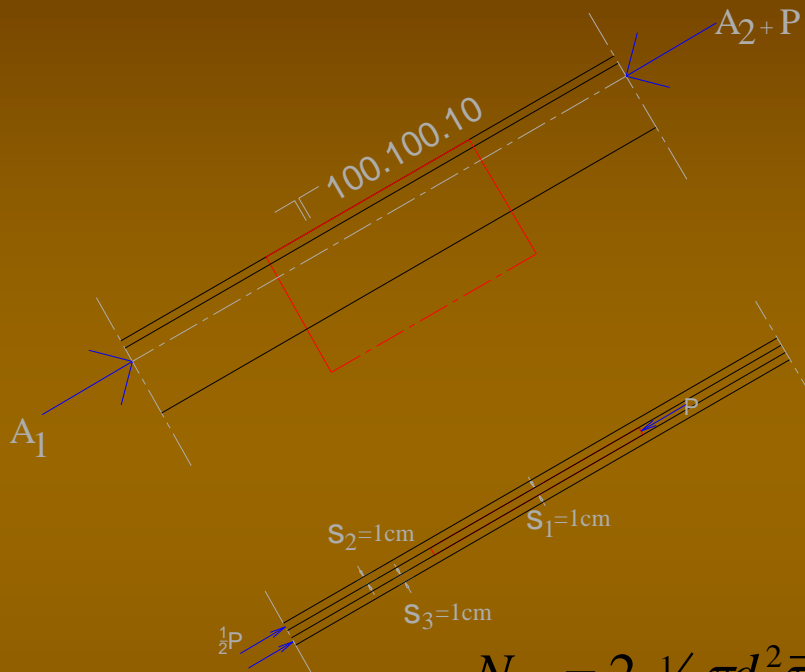

$$\begin{aligned}
 P &= A_1 - A_2 \\
 &= -4000\text{kg} + 2000\text{ kg} \\
 &= - 2000\text{ kg}
 \end{aligned}$$

$s_1 = s_2 \rightarrow s_1 = s_{\min} = 1\text{ cm}$
 pk $\varnothing 20\text{ mm}$ (lubang)
 Sambungan dobel

$$N_{gs} = 2 \cdot \frac{1}{4} \pi d^2 \bar{\tau} = 2 \cdot \frac{1}{4} \cdot 3,14 \times (2\text{cm})^2 \times 1120\text{ kg/cm}^2 = 7034\text{kg}$$

$$N_{tp} = d \cdot s_{\min} \bar{\sigma}_{tp} = 2\text{cm} \times 1\text{cm} \times 2800\text{ kg/cm}^2 = 5600\text{kg}$$

$$N_{\min} = N_{tp} = 5600\text{kg}$$

$$n = \frac{P_2}{N_{\min}} = \frac{2000\text{kg}}{5600\text{kg}} = 0,357 \approx 1 \Rightarrow \text{ambil } 2\varnothing 20\text{mm}$$

Gambar sket sambungan paku keling



b) Sambungan las sudut

Sambungan batang D_1 dengan plat simpul

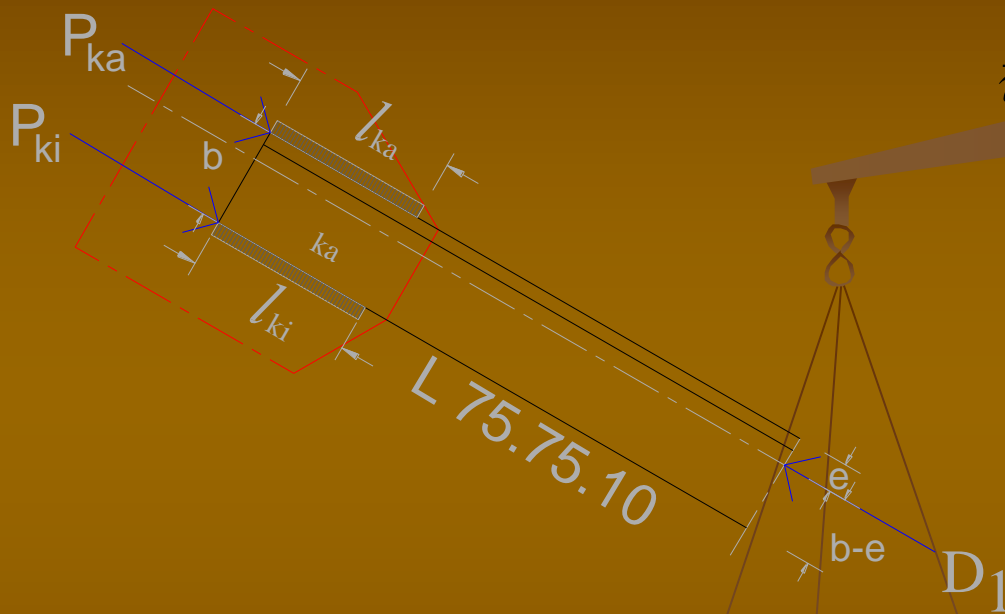

$$\bar{\tau} = 0,6\bar{\sigma} = 840 \text{ kg/cm}^2$$

$$D_1 = -2000 \text{ kg}$$

$$L\ 75.75.10$$

Dari tabel profil, utk $L\ 75.75.10$ didapat:

$$b = 75 \text{ mm} = 7,5 \text{ cm};$$

$$d = 10 \text{ mm} = 1 \text{ cm}; e = 2,21 \text{ cm}$$

$$d = 1 \text{ cm} \rightarrow a = 0,707d$$

$$a = 0,707 \times 1 \text{ cm} = 0,707 \text{ cm}$$

$$b - e = 7,5 \text{ cm} - 2,21 \text{ cm} = 5,29 \text{ cm}$$

$$\Sigma M_B = 0$$

$$P_{ka} \cdot b - P_1 \cdot (b - e) = 0$$

$$P_{ka} = \frac{P_1 \cdot (b - e)}{b} = \frac{2000 \text{ kg} \times 5,29 \text{ cm}}{7,5 \text{ cm}} = 1410 \text{ kg}$$

$$\Sigma H = 0$$

$$P_{ka} + P_{ki} - P_1 = 0$$

$$P_{ki} = P_1 - P_{ka}$$

$$P_{ki} = 2000 \text{ kg} - 1410 \text{ kg} = 590 \text{ kg}$$

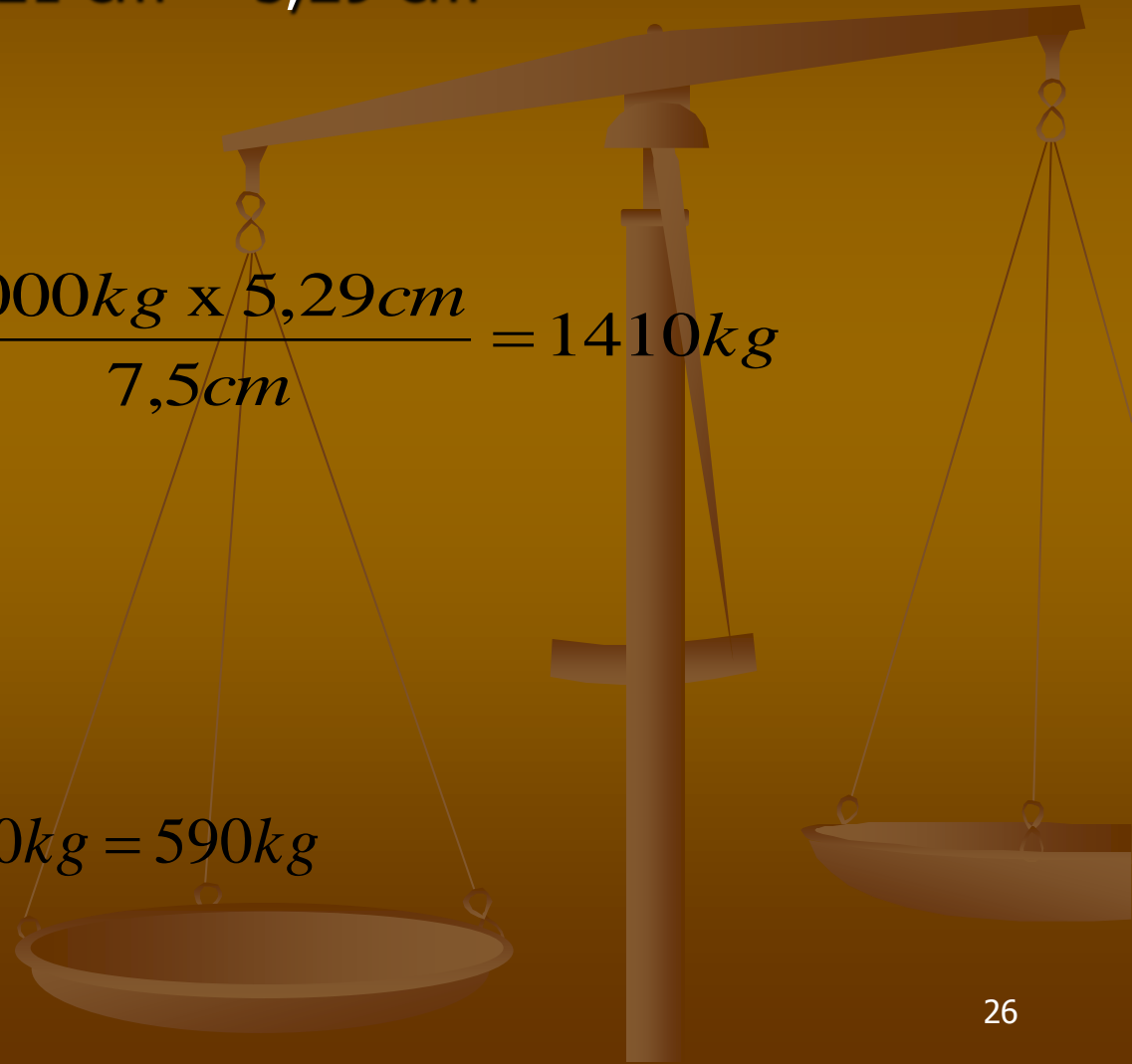

$$\tau_{ka} = \frac{P_{ka}}{F_{gska}} \Rightarrow \text{ambil } \tau_{ka} = \bar{\tau} = 840 \text{ kg/cm}^2$$

$$F_{gska} = \frac{P_{ka}}{\bar{\tau}} = \frac{1410 \text{ kg}}{840 \text{ kg/cm}^2} = 1,679 \text{ cm}^2$$

$$F_{gska} = a.l_{kan} = 0,707 \text{ cm}.l_{kan}$$

$$1,679 \text{ cm}^2 = 0,707 \text{ cm}.l_{kan}$$

$$l_{kan} = \frac{1,679 \text{ cm}^2}{0,707 \text{ cm}} = 2,375 \text{ cm}$$

$$l_{kabr} = l_{kan} + 3a = 2,375 \text{ cm} + (3 \times 0,707 \text{ cm})$$

$$l_{kabr} = 4,496 \text{ cm} \Rightarrow \text{ambil } l_{kabr} = 5 \text{ cm}$$

panjang las kanan = 5 cm

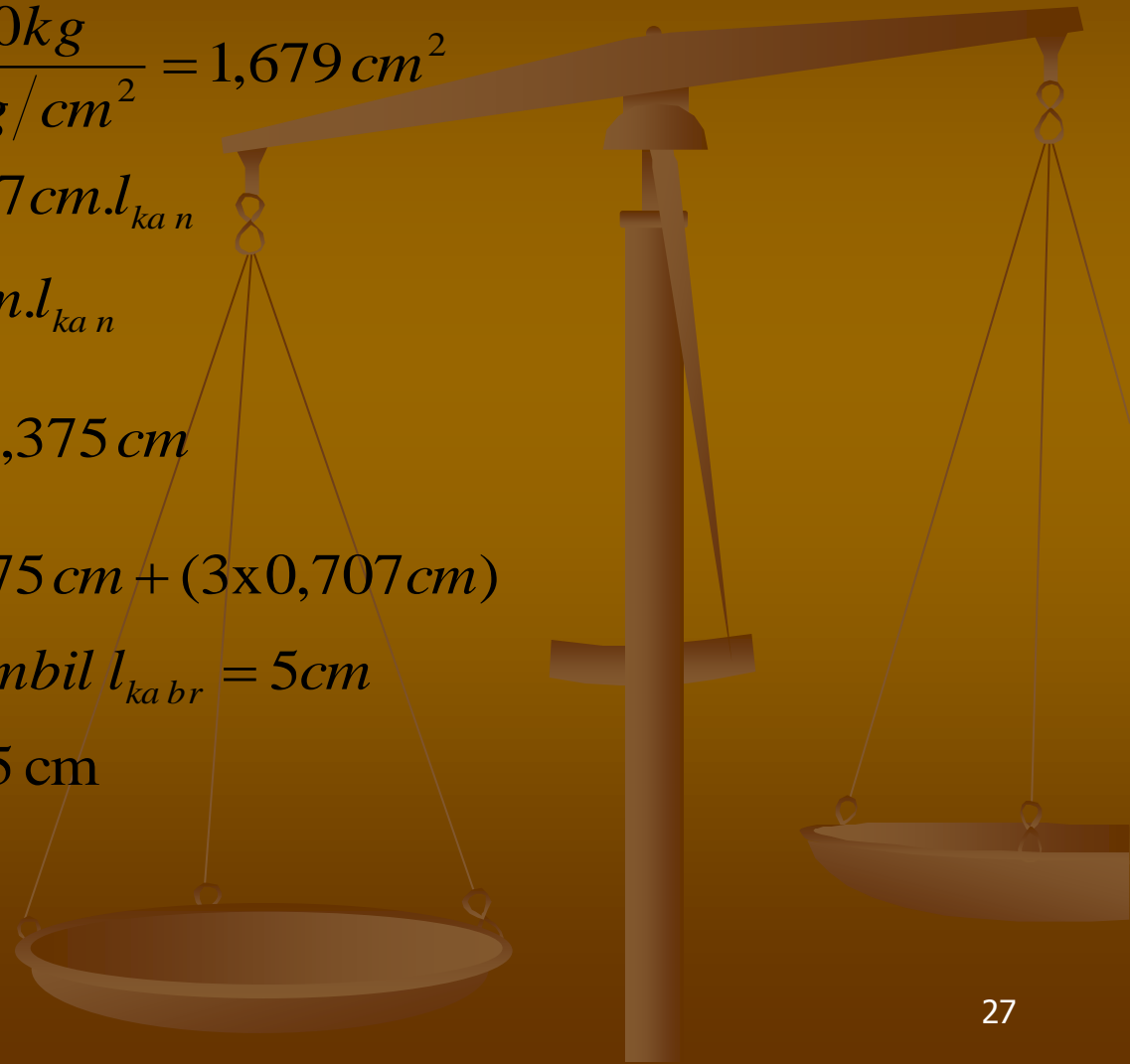

$$\tau_{ki} = \frac{P_{ki}}{F_{gs ki}} \Rightarrow \text{ambil } \tau_{ki} = \bar{\tau} = 840 \text{ kg/cm}^2$$

$$F_{gs ki} = \frac{P_{ki}}{\bar{\tau}} = \frac{590 \text{ kg}}{840 \text{ kg/cm}^2} = 0,702 \text{ cm}^2$$

$$F_{gs ki} = a.l_{ki n} = 0,707 \text{ cm}.l_{ki n}$$

$$0,702 \text{ cm}^2 = 0,707 \text{ cm}.l_{ki n}$$

$$l_{ki n} = \frac{0,702 \text{ cm}^2}{0,707 \text{ cm}} = 0,993 \text{ cm}$$

$$l_{ki br} = l_{ki n} + 3a = 0,993 \text{ cm} + (3 \times 0,707 \text{ cm})$$

$$l_{ki br} = 3,114 \text{ cm} < l_{\min} = 4 \text{ cm} \Rightarrow \text{ambil } l_{ki br} = 4 \text{ cm}$$

panjang las kiri = 4 cm

Batang $T_1 = 2000 \text{ kg}$; L 75.75.10 \rightarrow analog dgn perhit. las batang D_1 ; didapat :

Panjang las kiri = 4 cm

Panjang las kanan = 5 cm

Sambungan batang A₁ dan A₂ dengan plat simpul

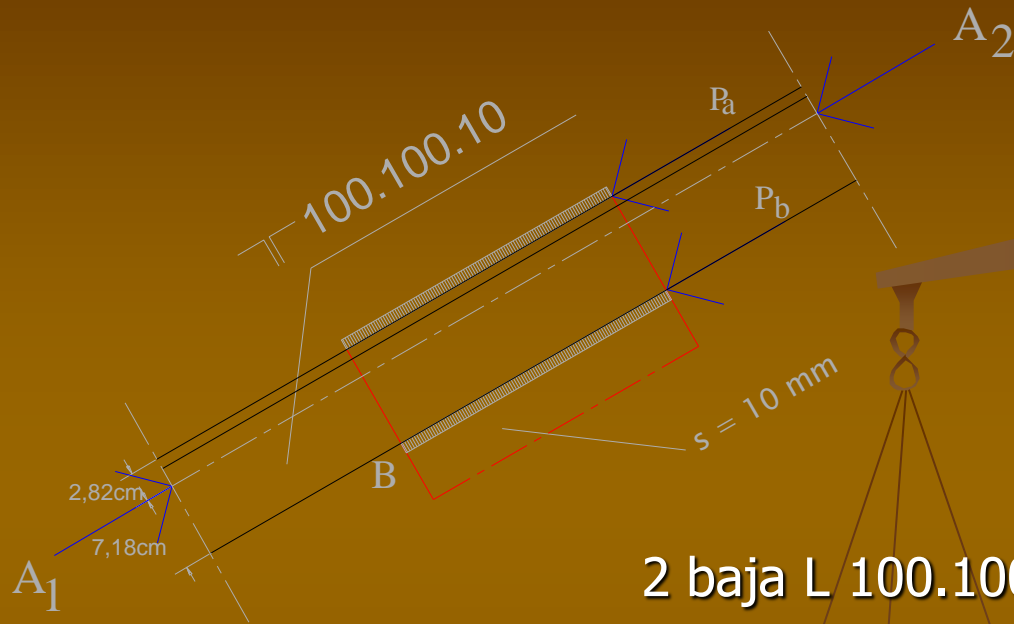

$$\begin{aligned}
 P &= A_1 - A_2 \\
 &= -4000\text{kg} + 2000\text{ kg} \\
 &= - 2000\text{ kg}
 \end{aligned}$$

$$\bar{\tau} = 0,6\bar{\sigma} = 840\text{ kg/cm}^2$$

2 baja L 100.100.10 menahan gaya P
 1 baja L 100.100.10 menahan gaya P₁ = P/2
 → P₁ = -- 2000 kg/2 = 1000 kg

Dari tabel profil, utk L 100.100.10 didapat:

b = 100 mm = 10 cm; d = 10 mm = 1 cm; e = 2,82 cm

$$d = 1 \text{ cm} \rightarrow a = 0,707d$$

$$a = 0,707 \times 1 \text{ cm} = 0,707 \text{ cm}$$

$$b - e = 10 \text{ cm} - 2,82 \text{ cm} = 7,18 \text{ cm}$$

$$\Sigma M_B = 0$$

$$P_a \cdot b - P_1 \cdot (b - e) = 0$$

$$P_a = \frac{P_1 \cdot (b - e)}{b} = \frac{1000 \text{ kg} \times 7,18 \text{ cm}}{10 \text{ cm}} = 718 \text{ kg}$$

$$\Sigma H = 0$$

$$P_a + P_b - P_1 = 0$$

$$P_b = P_1 - P_a$$

$$P_b = 1000 \text{ kg} - 718 \text{ kg} = 282 \text{ kg}$$

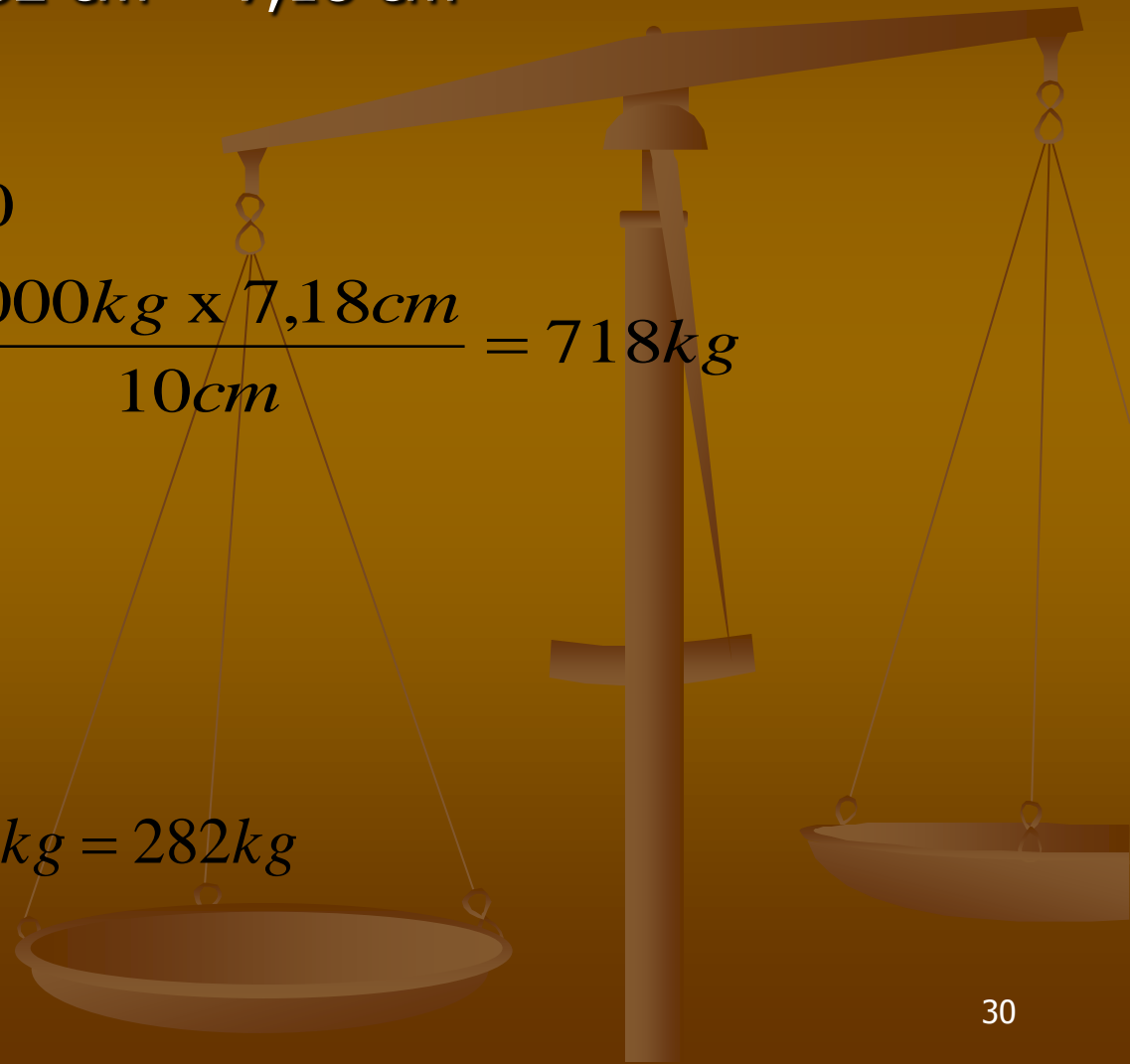

$$\tau_a = \frac{P_a}{F_{gsa}} \Rightarrow \text{ambil } \tau_a = \bar{\tau} = 840 \text{ kg/cm}^2$$

$$F_{gsa} = \frac{P_a}{\bar{\tau}} = \frac{718 \text{ kg}}{840 \text{ kg/cm}^2} = 0,855 \text{ cm}^2$$

$$F_{gsa} = a.l_{an} = 0,707 \text{ cm}.l_{an}$$

$$0,855 \text{ cm}^2 = 0,707 \text{ cm}.l_{an}$$

$$l_{an} = \frac{0,855 \text{ cm}^2}{0,707 \text{ cm}} = 1,209 \text{ cm}$$

$$l_{abr} = l_{an} + 3a = 1,209 \text{ cm} + (3 \times 0,707 \text{ cm})$$

$$l_{abr} = 3,33 \text{ cm} < l_{\min} = 4 \text{ cm} \Rightarrow \text{ambil } l_{abr} = 4 \text{ cm}$$

panjang las atas = 4 cm \Rightarrow dipasang secukupnya

$$\tau_b = \frac{P_b}{F_{gsb}} \Rightarrow \text{ambil } \tau_b = \bar{\tau} = 840 \text{ kg/cm}^2$$

$$F_{gsb} = \frac{P_b}{\bar{\tau}} = \frac{282 \text{ kg}}{840 \text{ kg/cm}^2} = 0,336 \text{ cm}^2$$

$$F_{gsb} = a \cdot l_{bn} = 0,707 \text{ cm} \cdot l_{bn}$$

$$0,336 \text{ cm}^2 = 0,707 \text{ cm} \cdot l_{bn}$$

$$l_{bn} = \frac{0,336 \text{ cm}^2}{0,707 \text{ cm}} = 0,475 \text{ cm}$$

$$l_{bbr} = l_{bn} + 3a = 0,475 \text{ cm} + (3 \times 0,707 \text{ cm})$$

$$l_{bbr} = 2,596 \text{ cm} < l_{\min} = 4 \text{ cm} \Rightarrow \text{ambil } l_{bbr} = 4 \text{ cm}$$

panjang las bawah = 4 cm \Rightarrow dipasang secukupnya

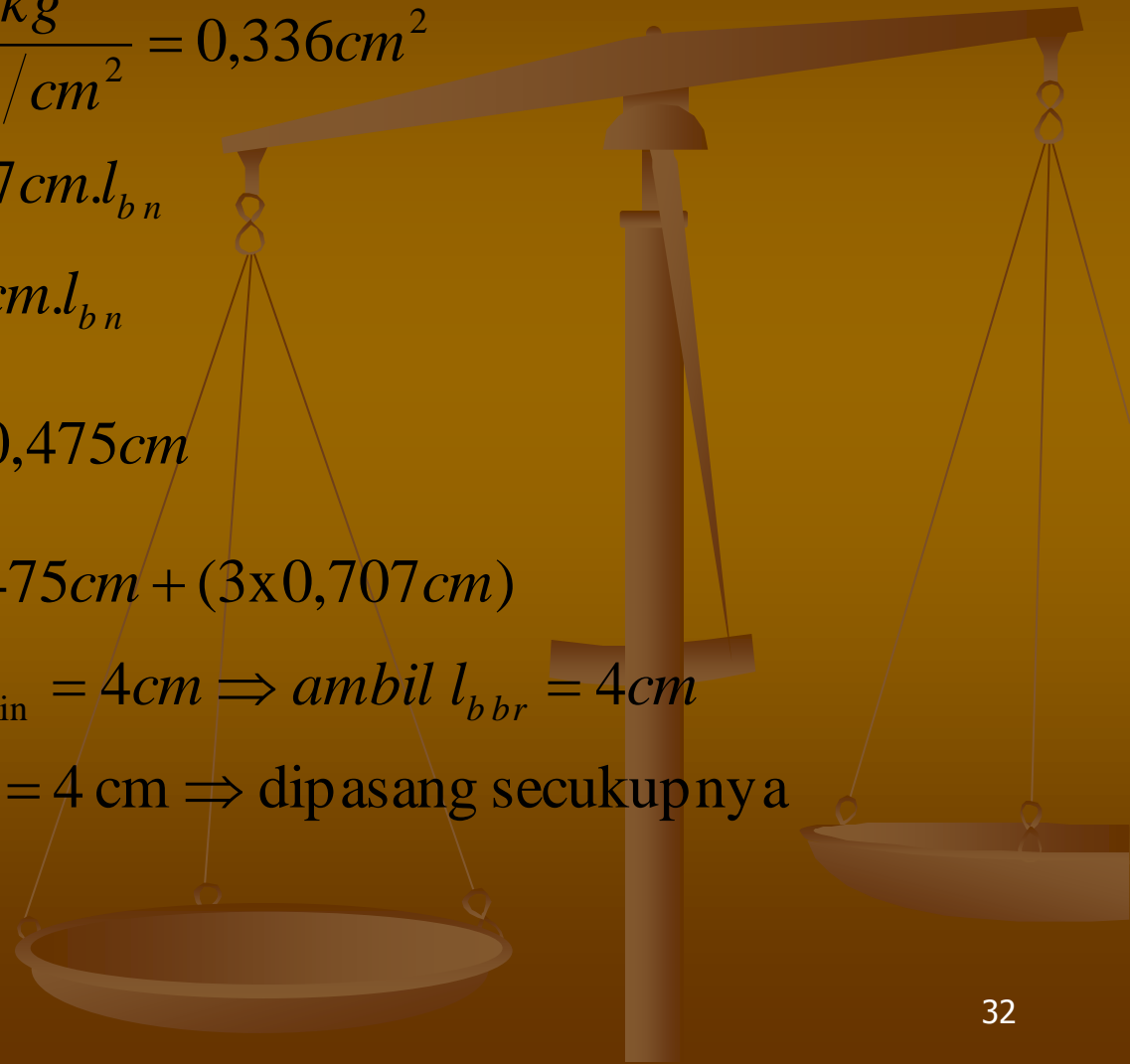

Gambar sket sambungan las sudut

