

CNC



PERKEMBANGAN CNC

- NC (*Numerical Control*) adalah system pengendalian mesin dengan menggunakan angka/numeric.
- CNC (*Computer Numerical Control*) pada prinsipnya sama dengan NC, yaitu sistem pengendalian mesin dengan menggunakan angka/numerik, tetapi memiliki kelebihan dibanding NC. Kelebihan tersebut diantaranya adalah kemampuan dalam menyimpan dan meningkatkan memori pada alat kendali.
- Menurut Pusztai (1983:8) mesin CNC adalah mesin yang terdiri dari *unit input, computing or mathematics unit, memory unit, control unit, and out put unit*.

PENGENDALIAN MESIN NC

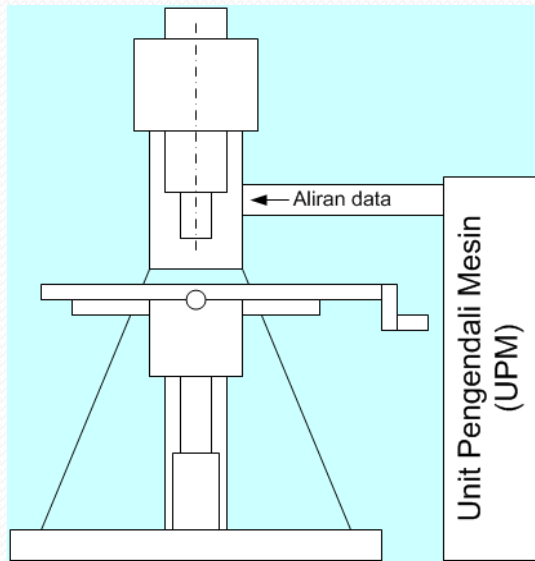

Gambar 1.1 Prinsip Pengoperasian Mesin NC

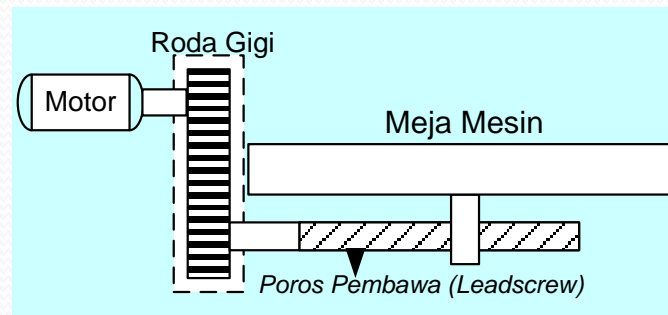

Gambar 1.2 Prinsip pengendalian gerakan sumbu mesin

STRUKTUR PENGOPERASIAN MESIN NC

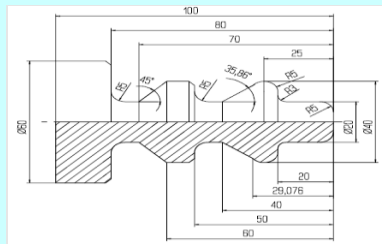

Gambar kerja

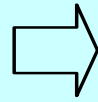

```
G0 X500 Z500 T020202 M3 M42 M63
G96 S200
G50 S3000
G0 X62 Z0
G1 X-1 F0.15 M8
G0 X16 Z2
G86 NLAP1 D6 U0.4 W0.2 F0.3
```

Program

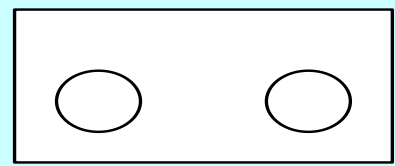
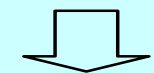

Alat Pembaca Data

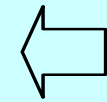

Pengendali

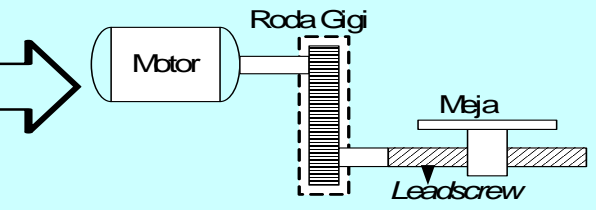
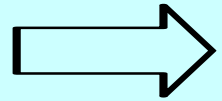

Media penyimpan program (pita berlubang)

MODEL PENGOPERASIAN MESIN CNC

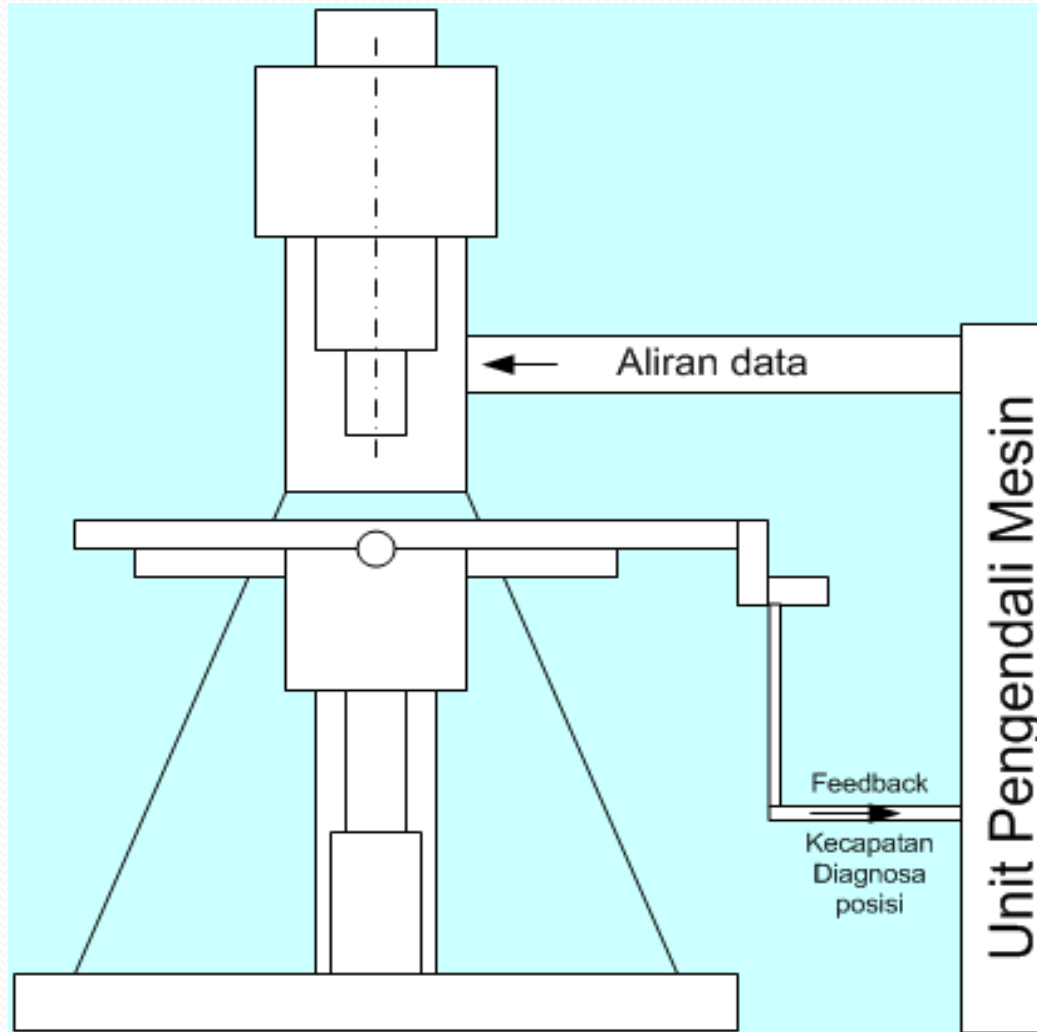

SISTIM PENGENDALIAN MESIN NON NC/CNC

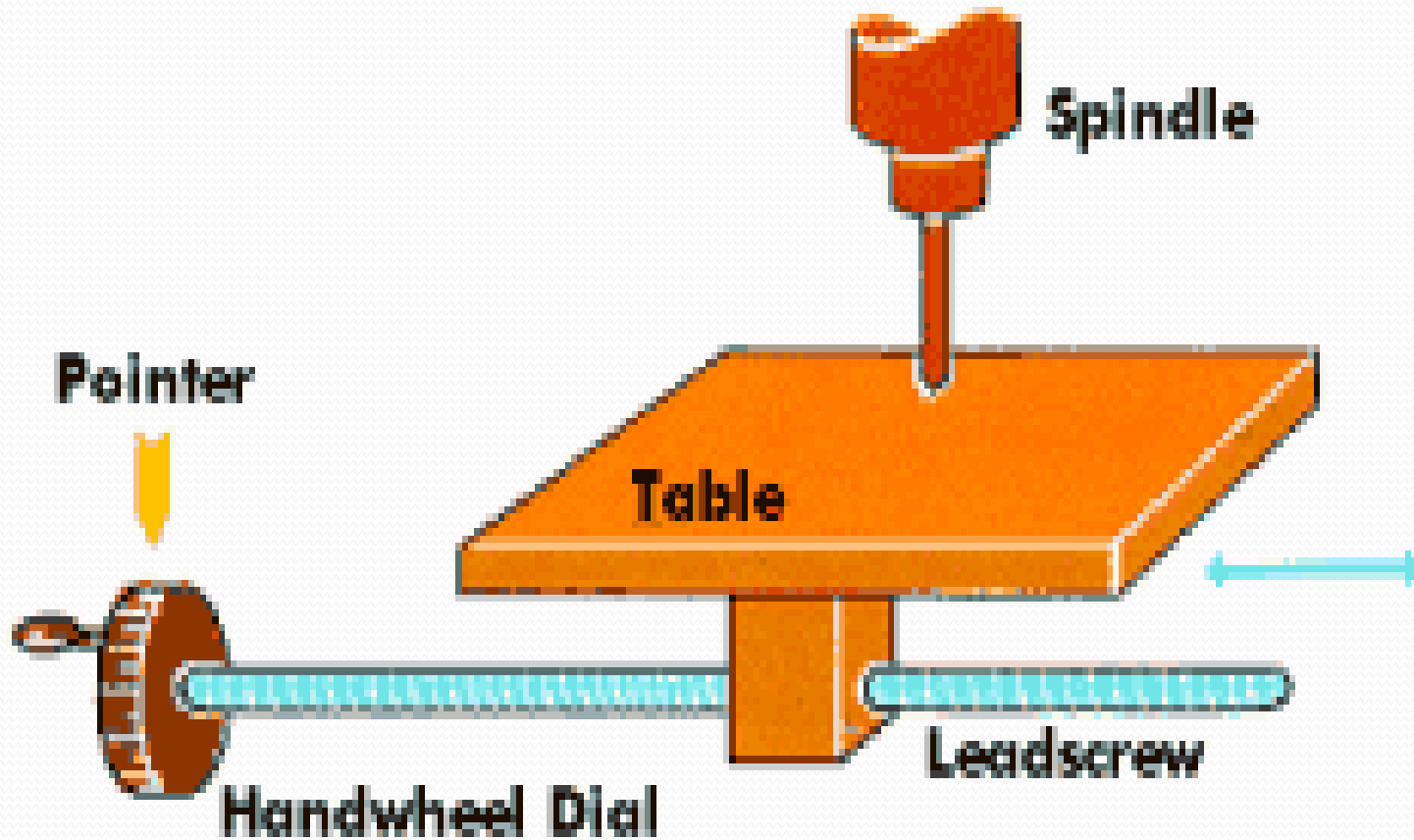

BAGIAN-BAGIAN MESIN CNC

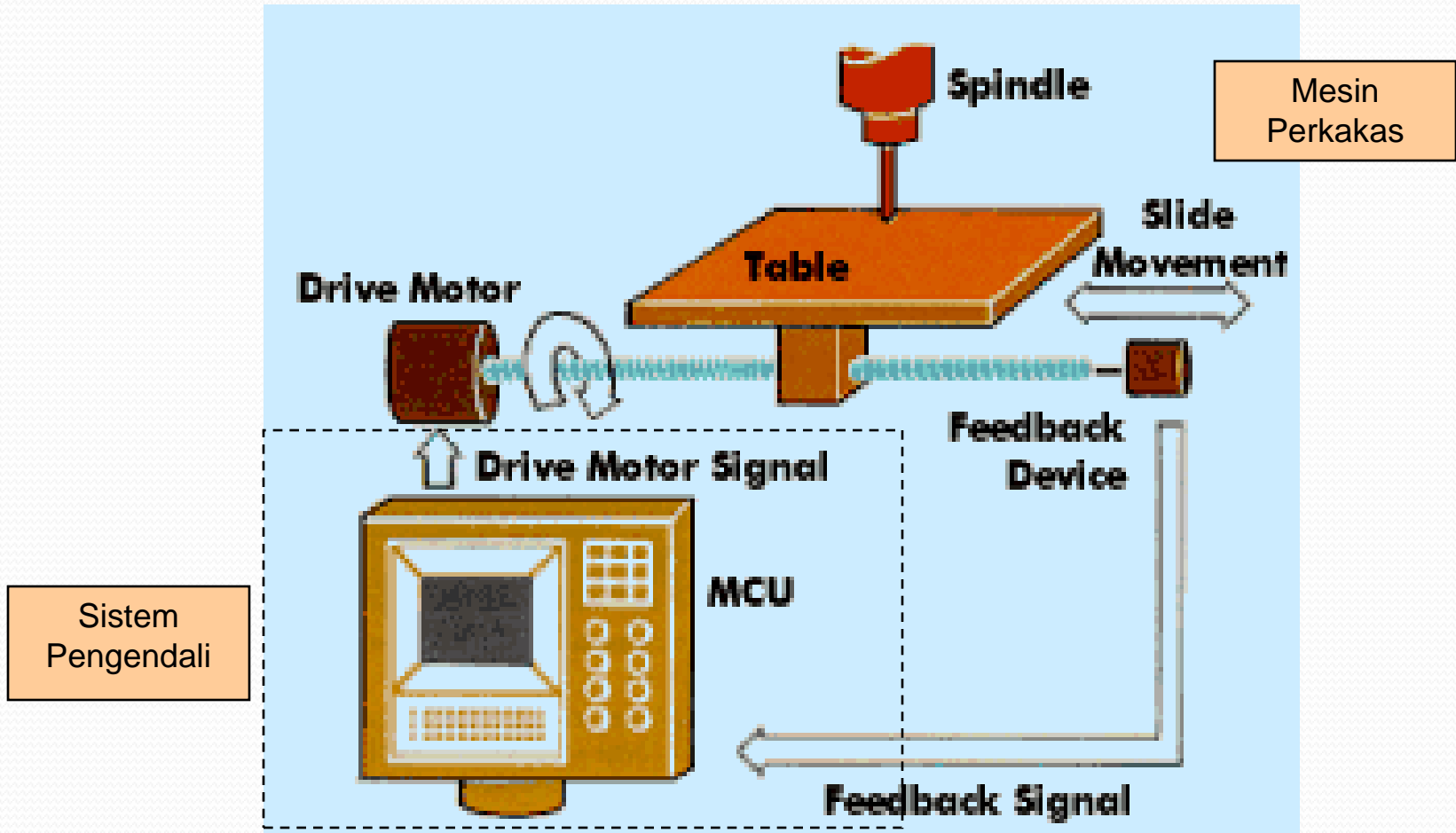

SISTIM PENGENDALI MESIN CNC

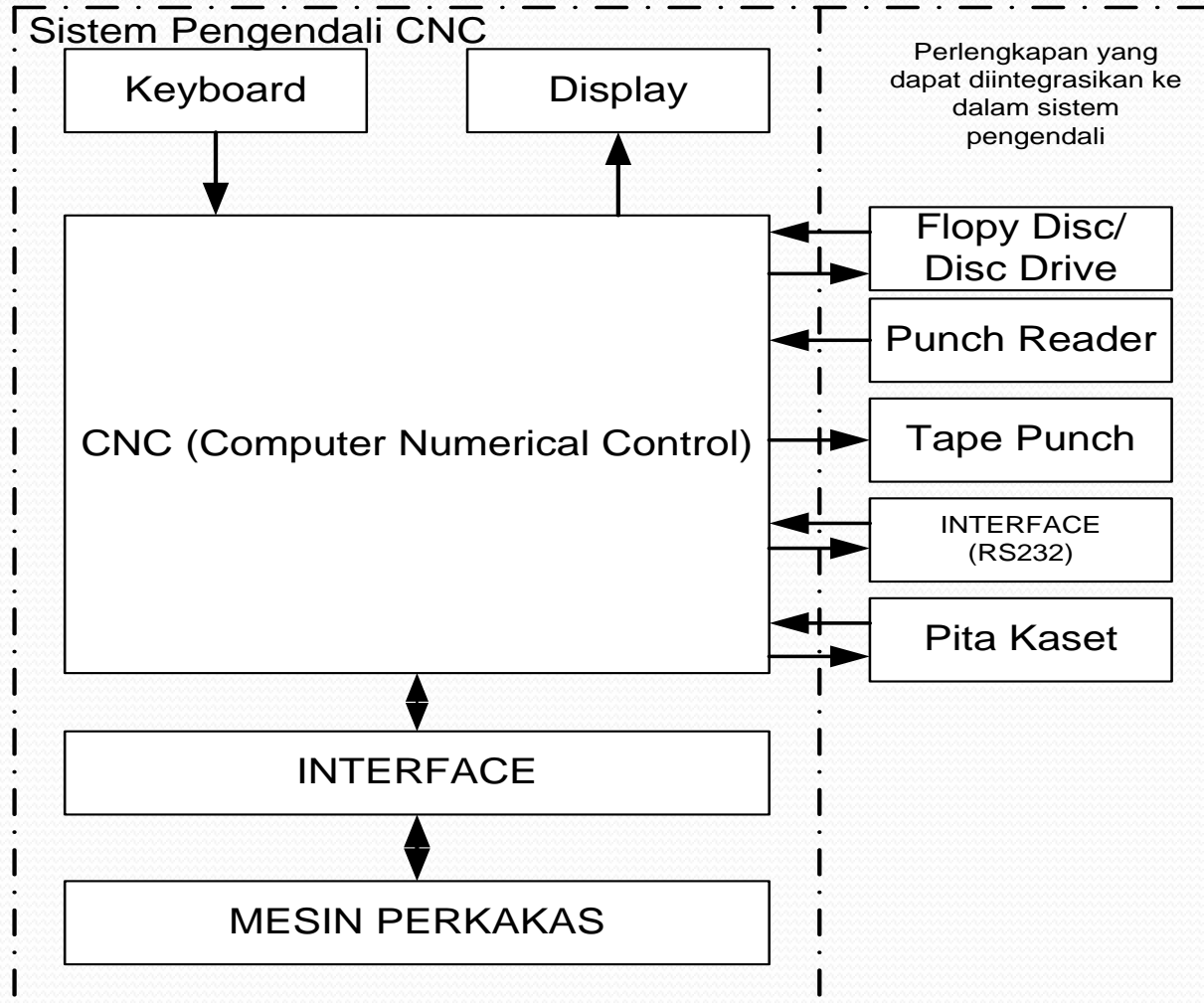

MESIN PERKAKAS

- Struktur mesin,
- Spindel dan sistem pencekam benda kerja,
- Sistem penggerak (Sistem penggerak spindel dan sistem penggerak sumbu),
- Sistem pengukur gerakan/langkah, dan
- sistem pengendalian alat potong.

HUBUNGAN ANTARA BAGIAN PENGENDALI DAN MESIN PERKAKAS PADA MESIN CNC

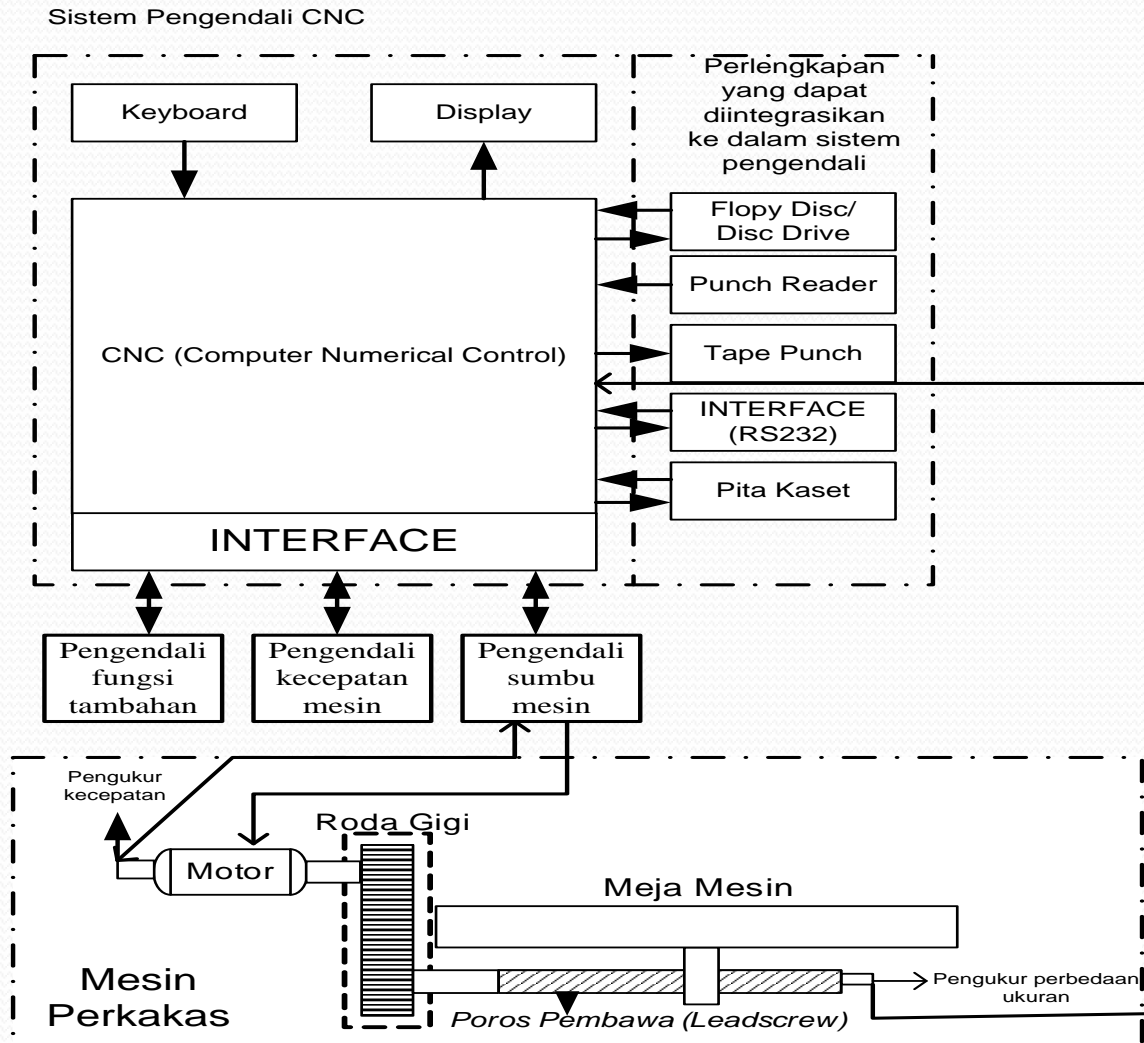

SISTEM PENGENDALI ALAT POTONG

- sebuah pemegang pahat (*tool holder*);
- sebuah tempat pemasangan mata pahat (*tool tip carrier*); dan
- sebuah atau beberapa mata pahat (*tools tips*).

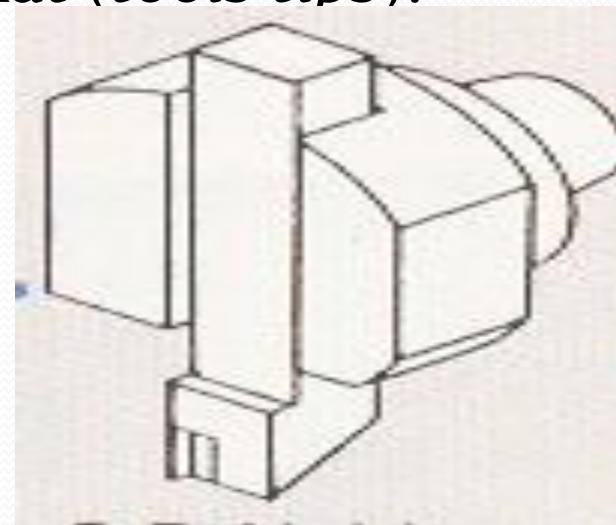
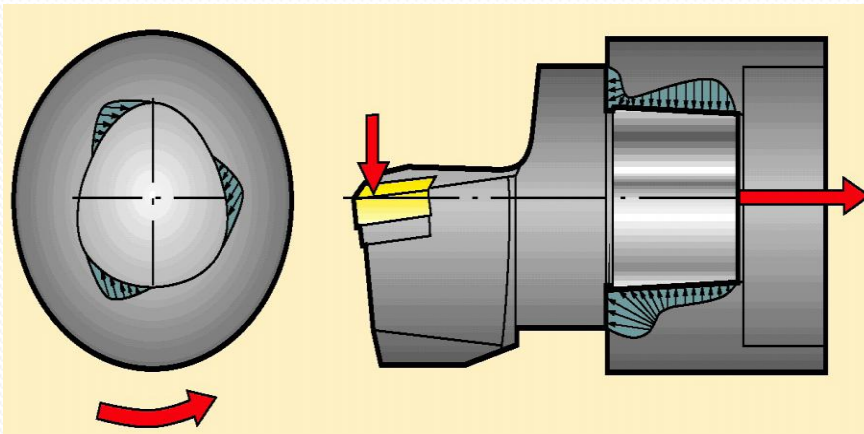

MACAM-MACAM PEMEGANG ALAT POTONG (TOOL HOLDER)

Cylindrical shank,

prismatic.

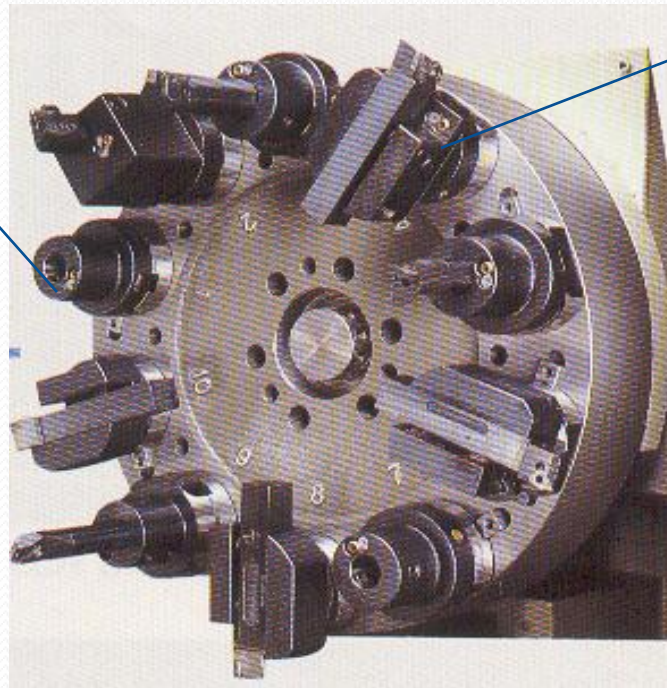

SISTEM PENGENDALIAN PADA MESIN CNC

Point-to-point

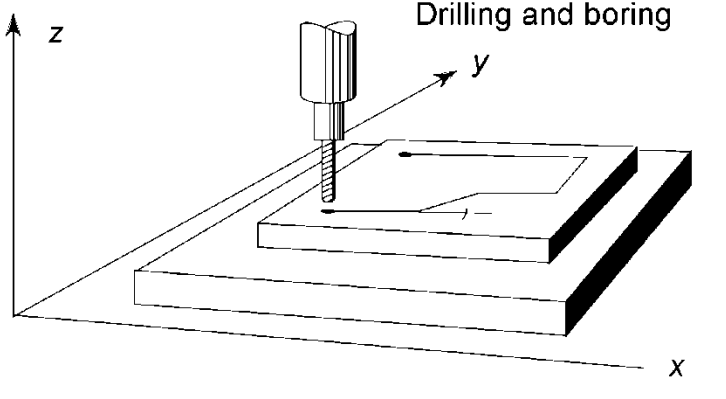

Point-to-point straight line

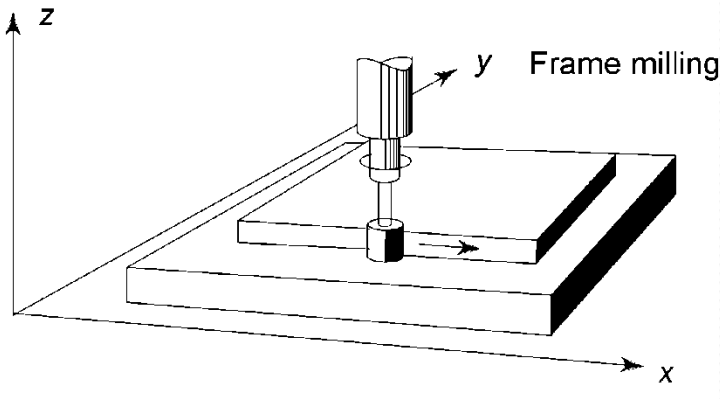

2 axis contouring with switchable plane

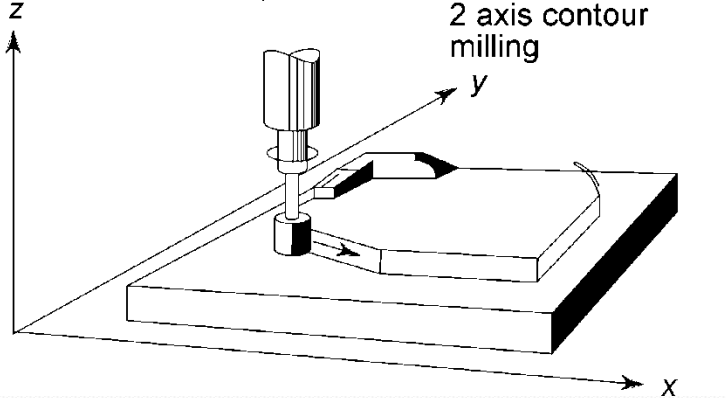

3 axis contouring continuous path

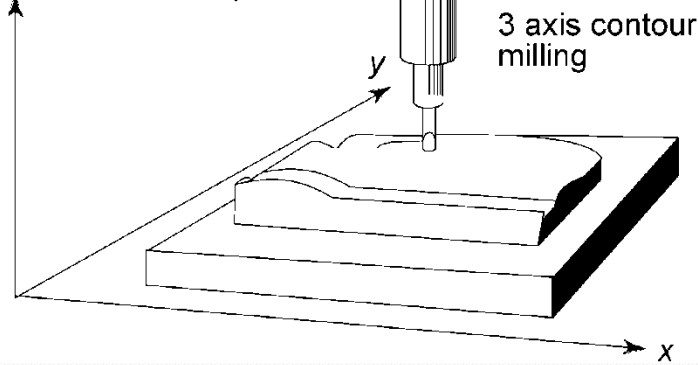

JENIS-JENIS ALAT POTONG

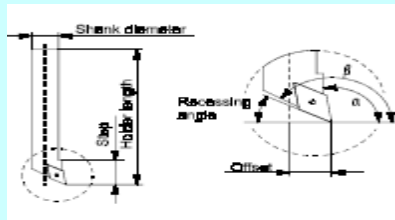

(a)

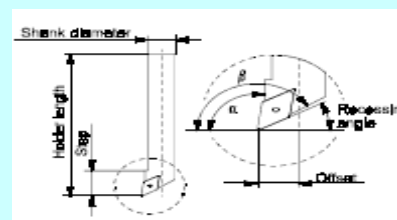

(b)

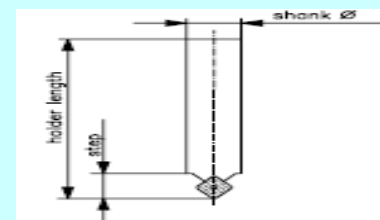

(c)

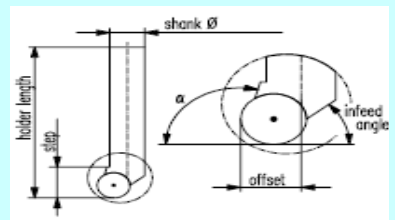

(d)

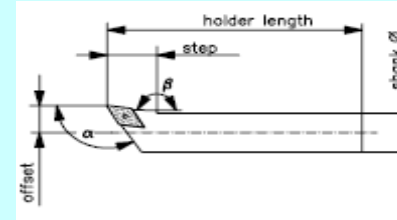

(e)

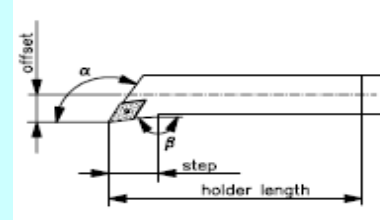

(f)

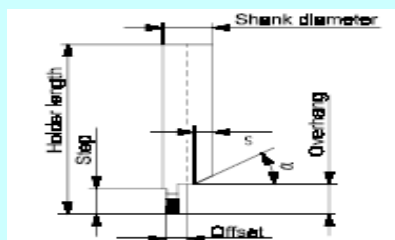

(g)

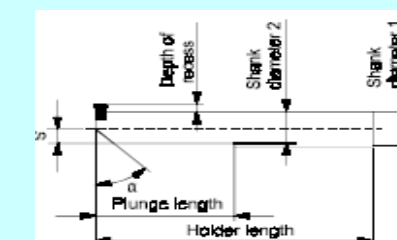

(h)

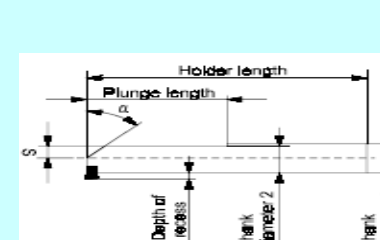

(i)

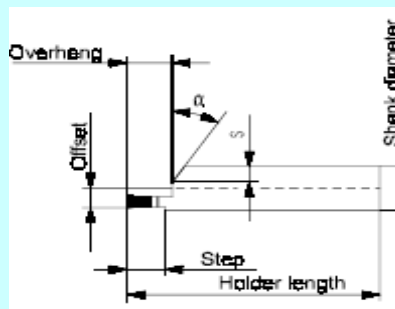

(j)

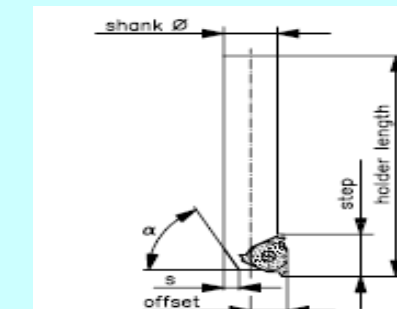

(k)

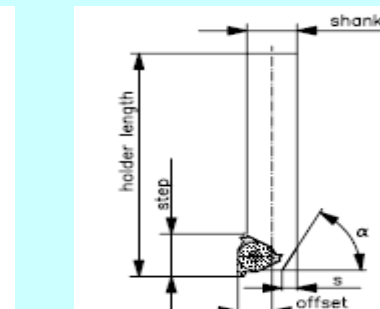

(l)

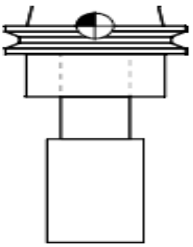
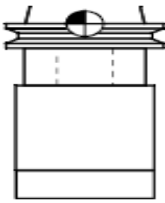
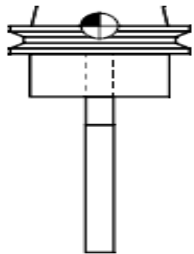
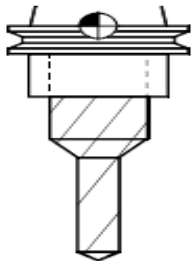
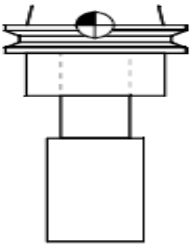
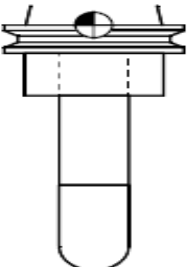
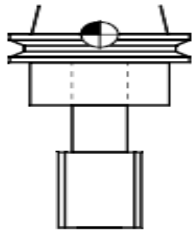
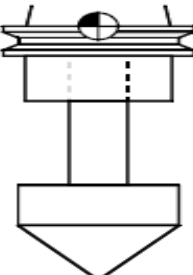
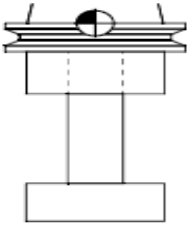
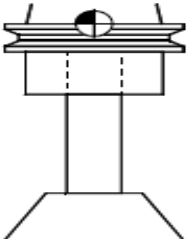
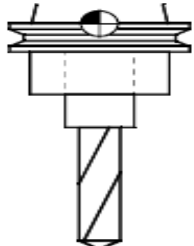
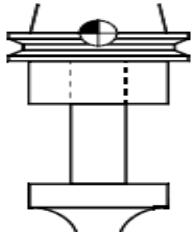
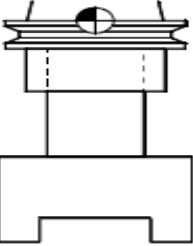
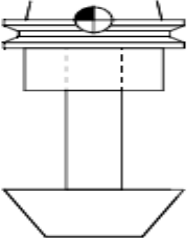
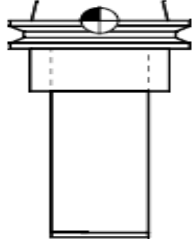
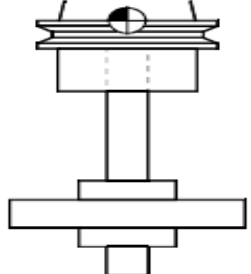
<p>End mills</p> 	<p>Face milling cutters</p> 	<p>Reamers</p> 	<p>Step drills</p> 
<p>Slot milling tools</p> 	<p>Radius cutters</p> 	<p>Taps</p> 	<p>Core drills</p> 
<p>T-slot cutters</p> 	<p>Corner tool (Type A)</p> 	<p>Drills</p> 	<p>Concave type cutters</p> 
<p>Shell end mills</p> 	<p>Corner tool (Type B)</p> 	<p>Insert tip drills</p> 	<p>Side milling tools</p> 

UKURAN ALAT POTONG

- ALAT POTONG BUBUT

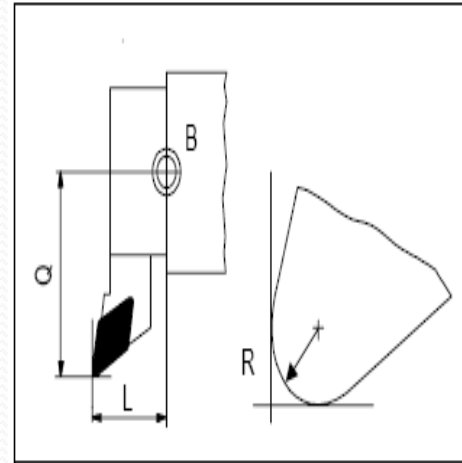

- B tool setup point
- L length = distance of the cutting tip to the tool set-in point in Z
- Q overhang = distance of the cutting tip to the tool setup point in X
- R cutting radius

- ALAT POTONG MILLING

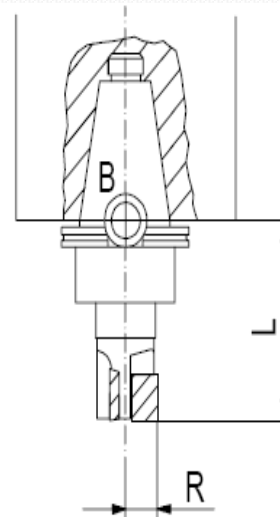

- B tool setup point
- L length = distance of the cutting tip to the tool setup point in Z
- R radius of the milling tool

DASAR-DASAR PEMROGRAMAN CNC

- SISTEM KOORDINAT

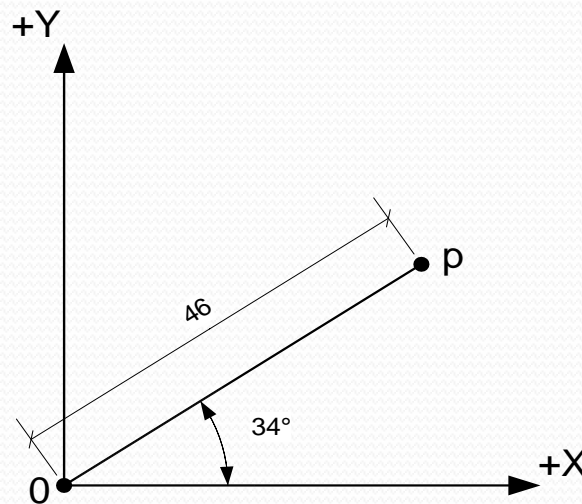
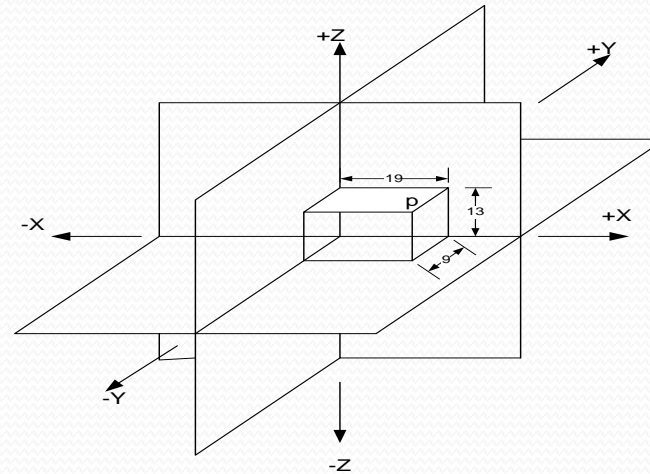
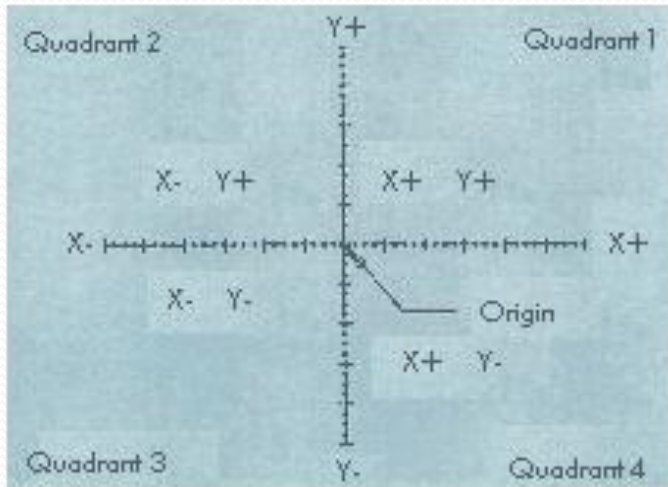

SISTIM SUMBU MESIN BUBUT CNC

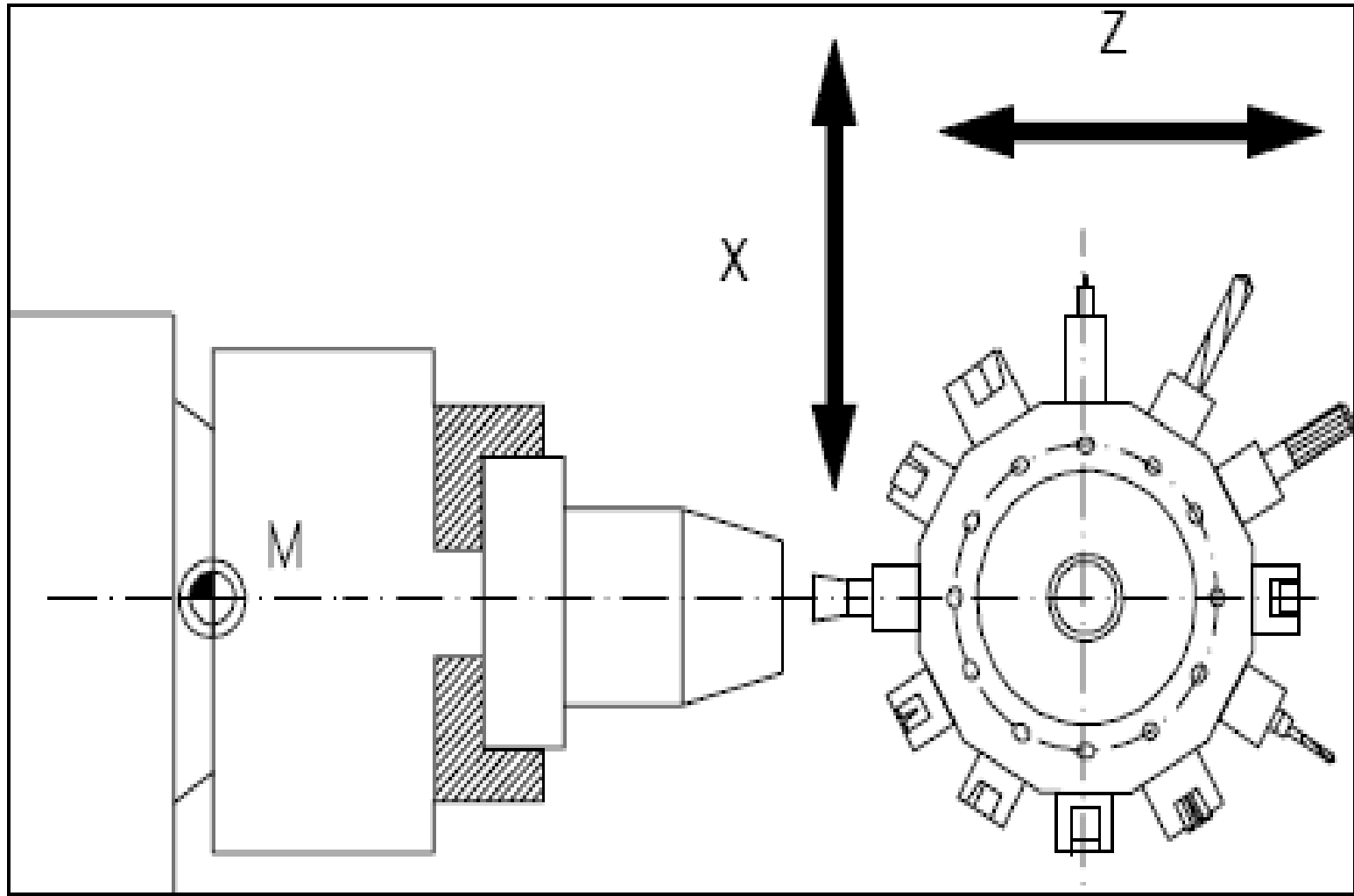

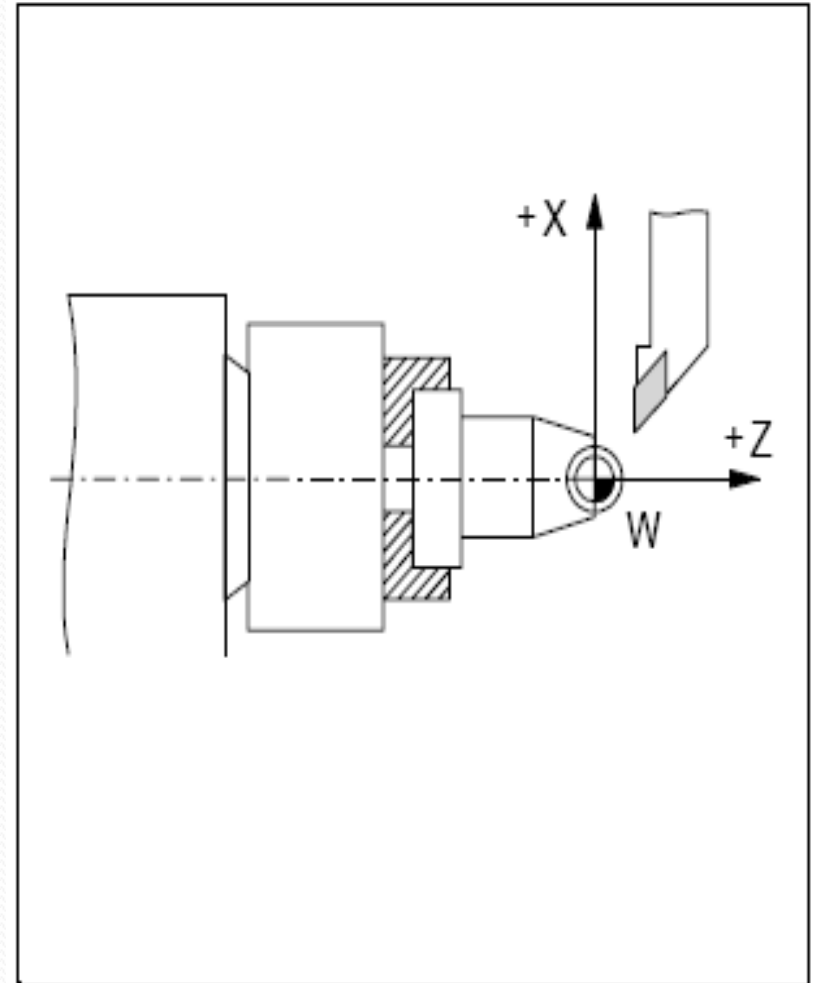
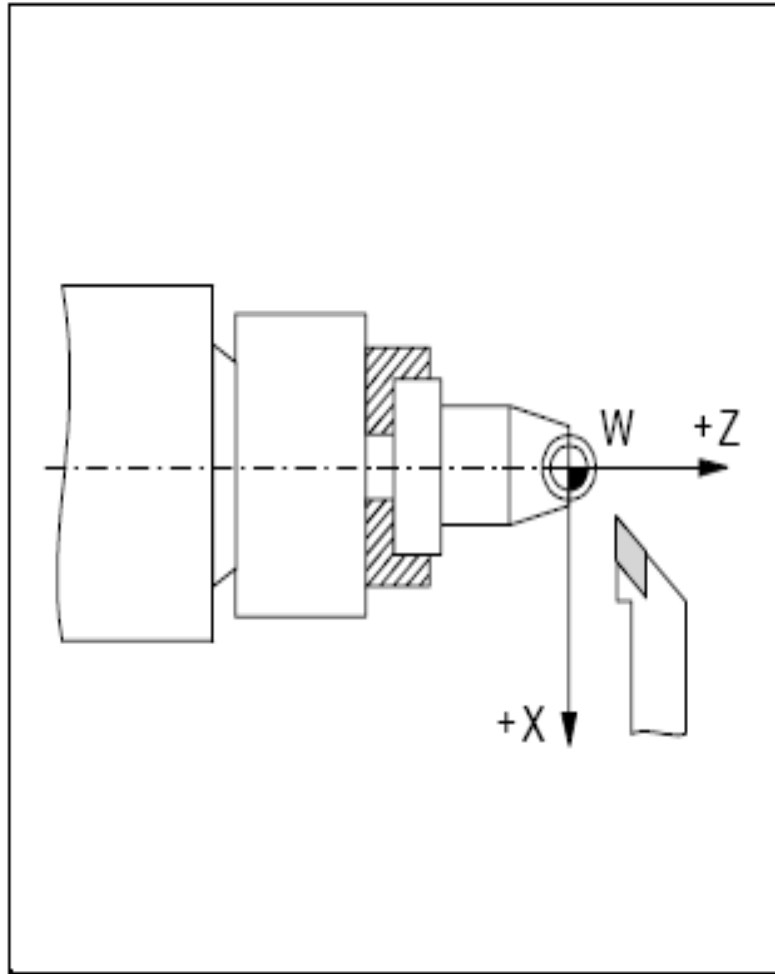

SISTEM SUMBU MESIN MILLING

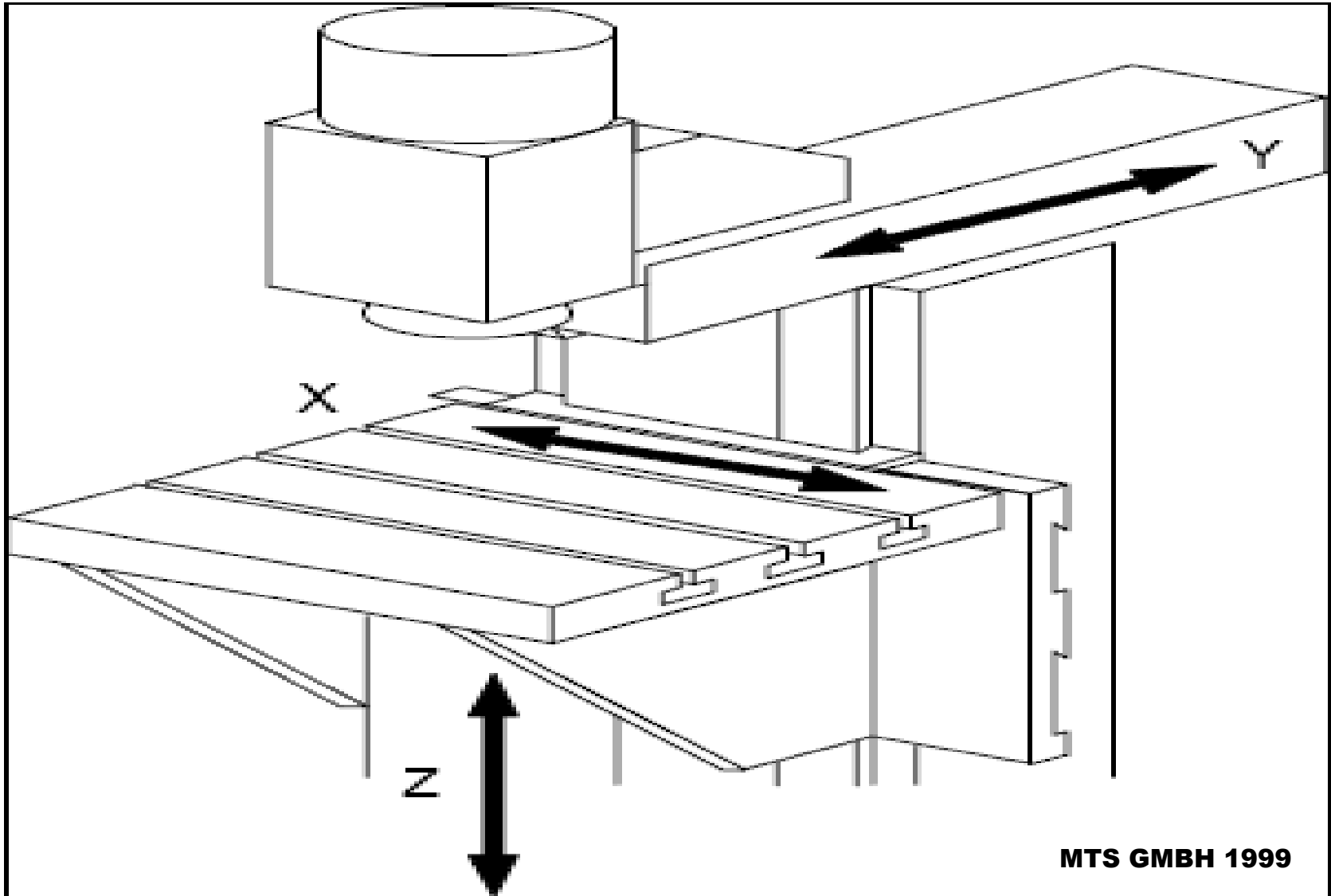

MTS GMBH 1999

SISTIM SUMBU MESIN MILLING CNC

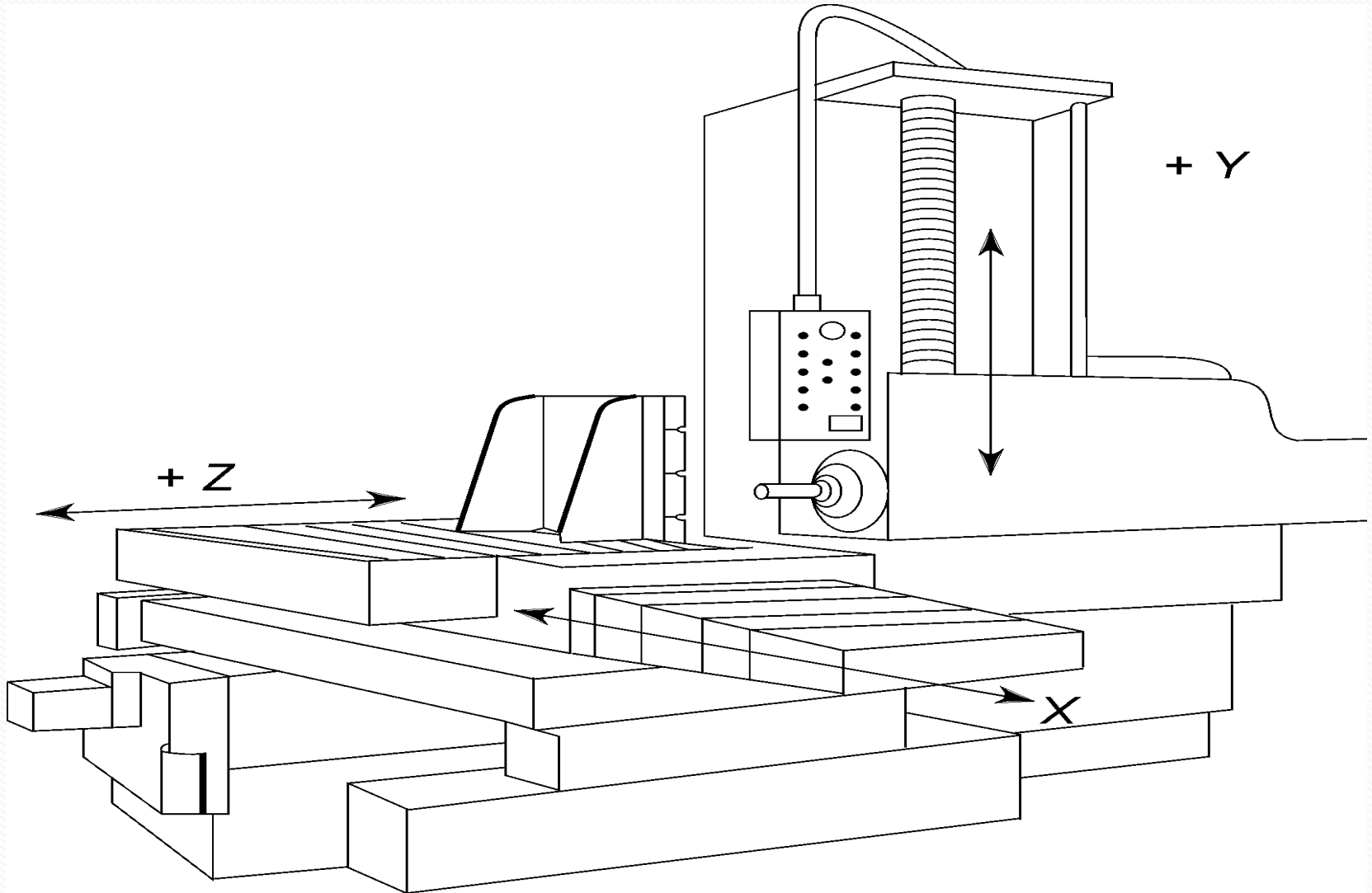

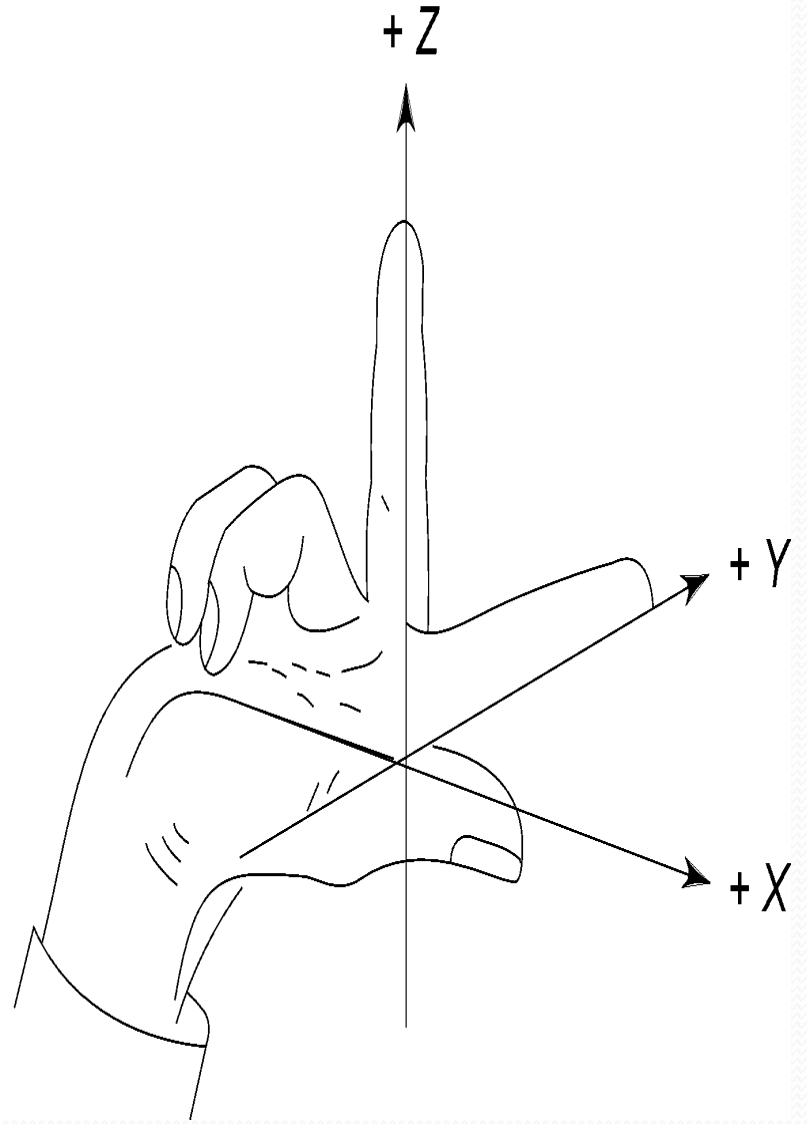
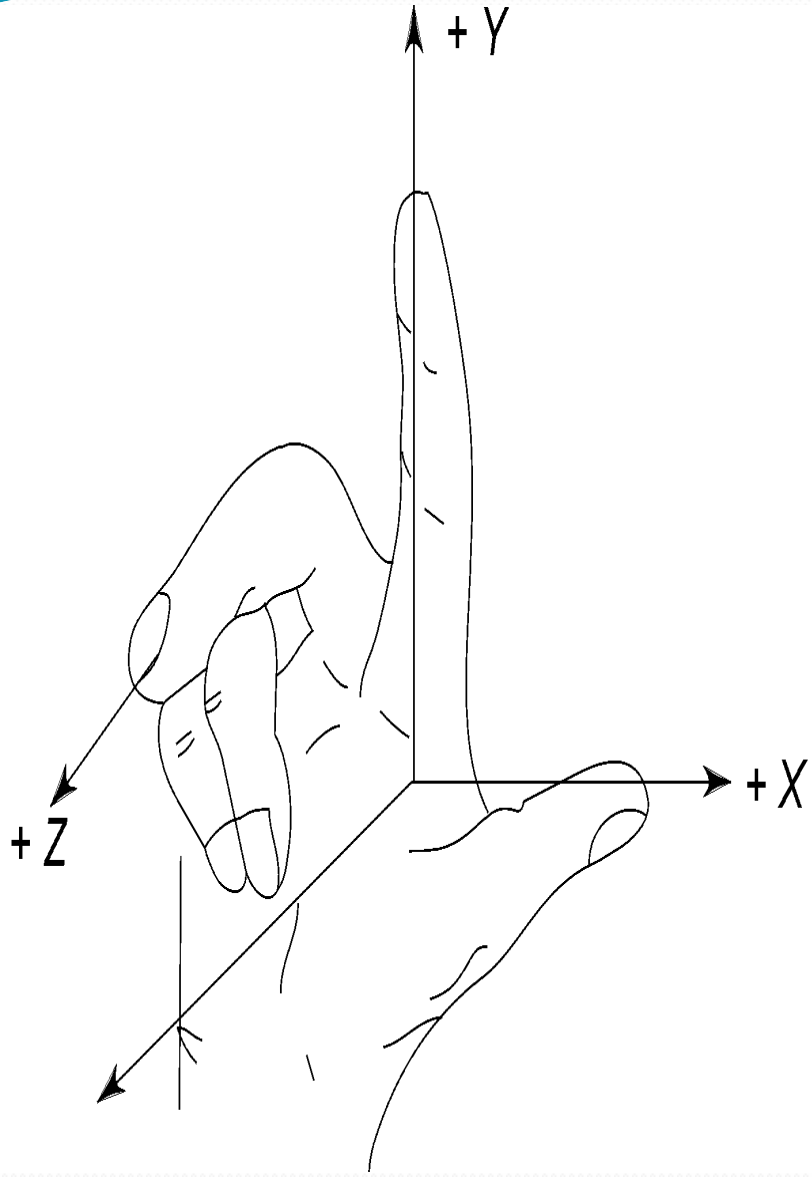



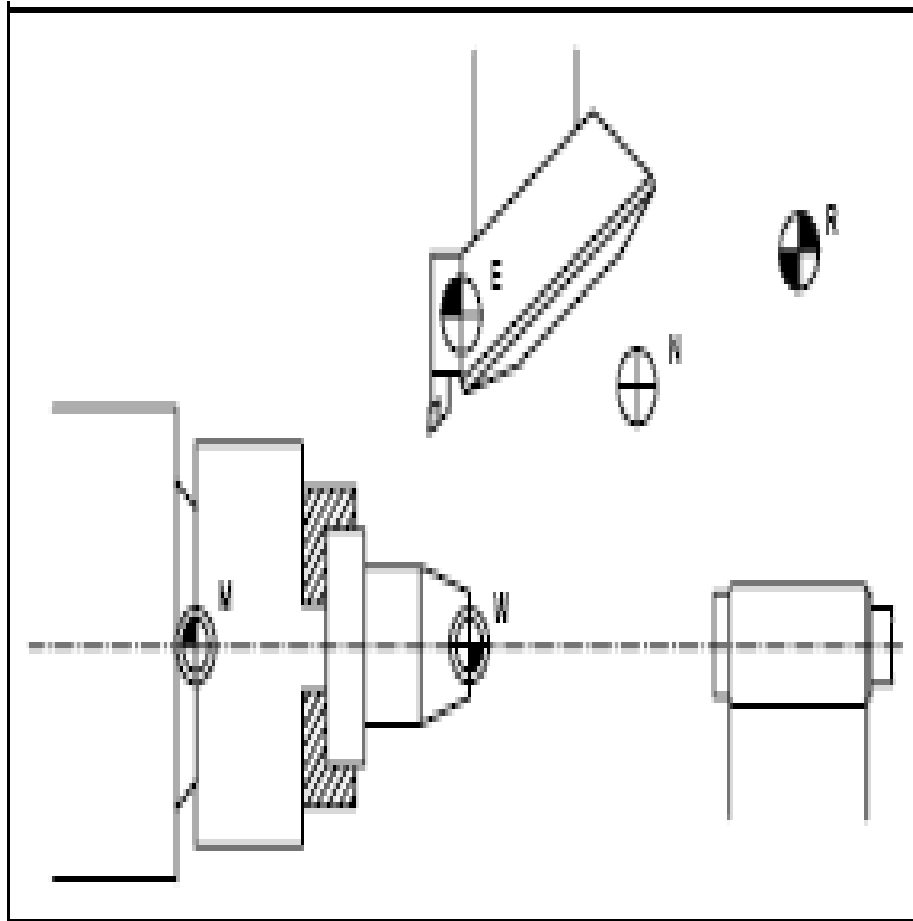

JENIS-JENIS TITIK ACUAN PADA MESIN CNC



Types of zero and reference points

- | | | |
|--|---|----------------------|
| | M | machine zero point |
| | W | work part zero point |
| | R | reference point |
| | E | tool reference point |
| | B | tool setup point |
| | A | tool shank point |
| | N | tool change point |

POSISI TITIK ACUAN PADA MESIN CNC

-  Machine zero
-  Reference point
-  Tool reference point
-  Workpart zero
-  Tool changing position

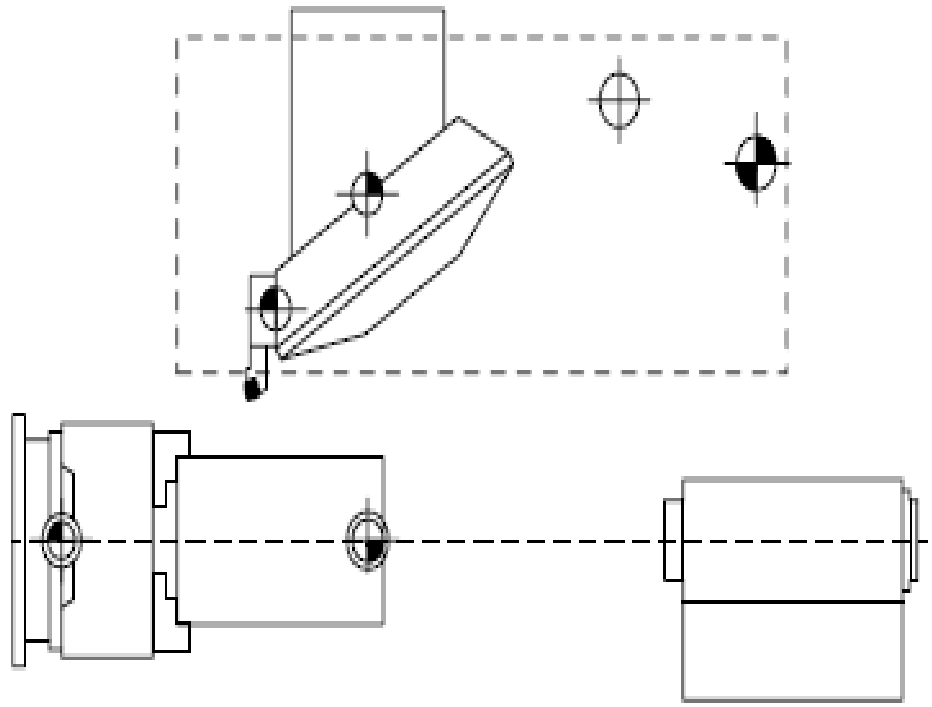

TITIK NOL MESIN

TITIK NOL MESIN FRAIS CNC

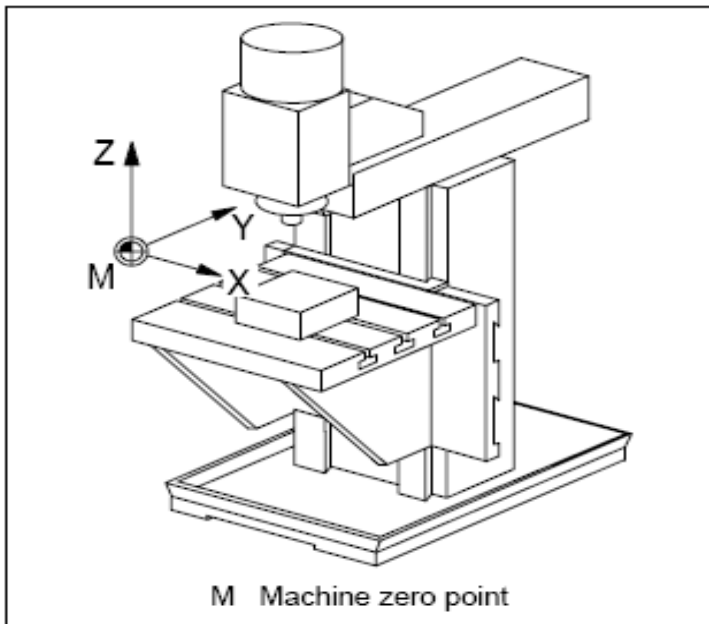

MTS GMBH 1999

TITIK NOL MESIN BUBUT CNC

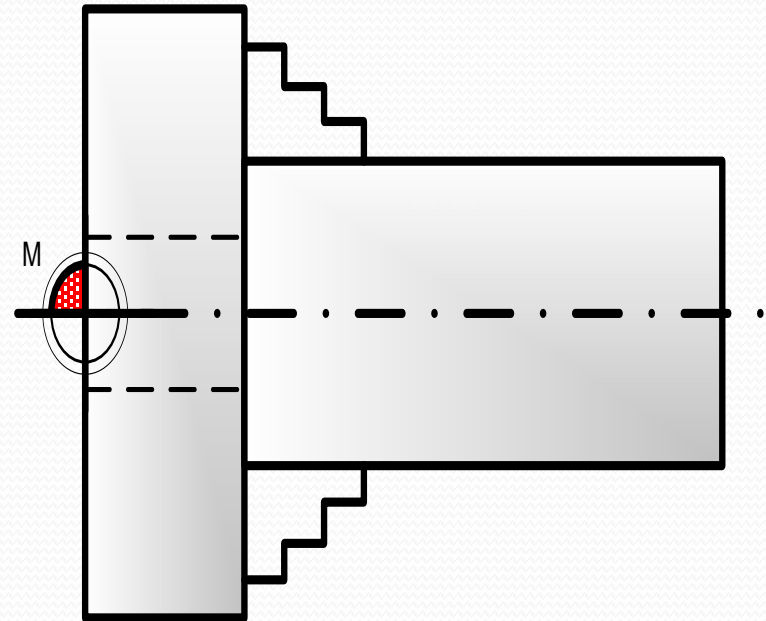

TITIK NOL BENDA KERJA

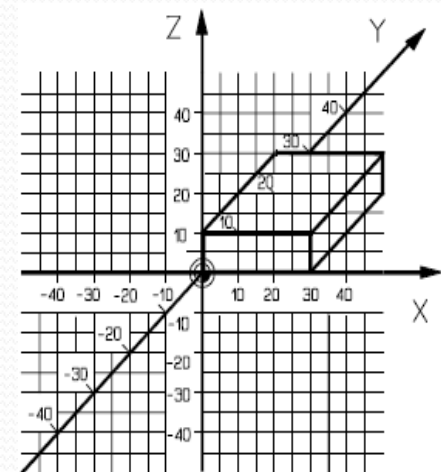
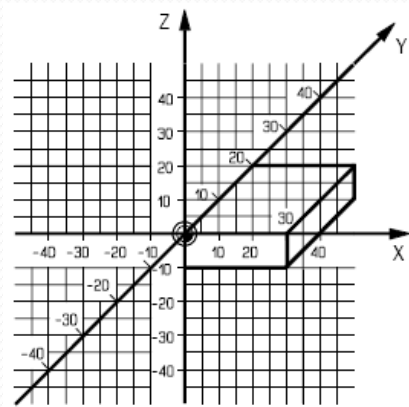
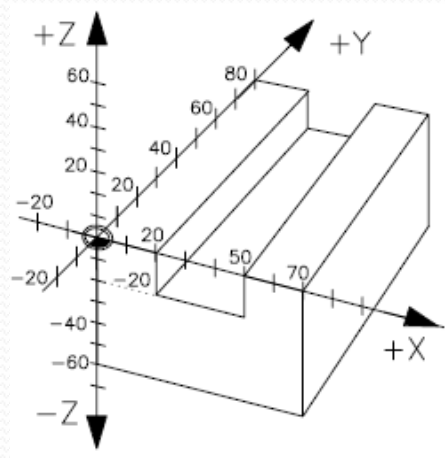
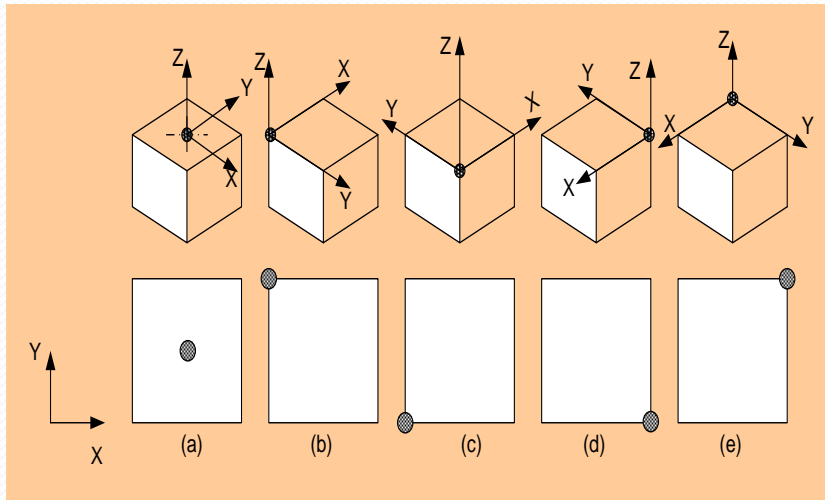

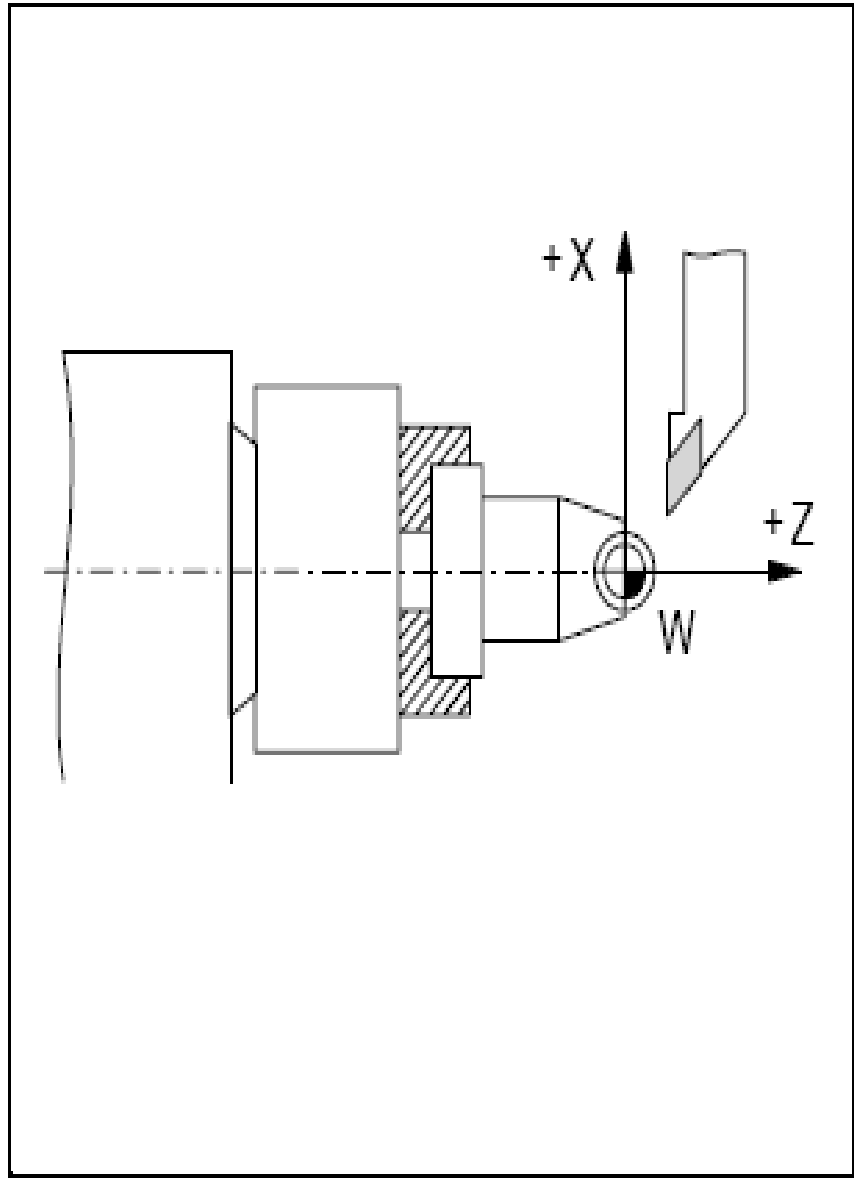
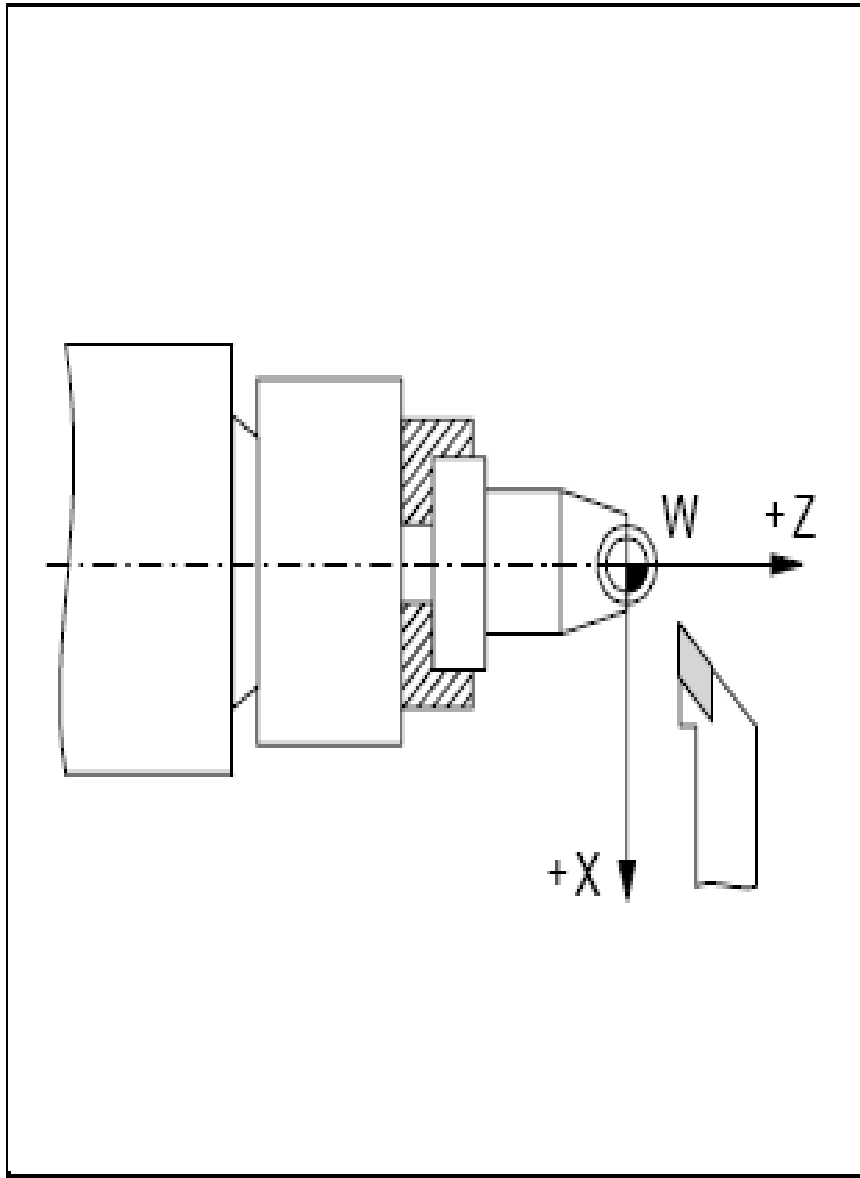

PERUBAHAN TITIK NOL MESIN KE TITIK NOL BENDA KERJA

